

STIHL

STIHL BR 500, 550, 600

Instruction Manual



Contents

1	Introduction	2	9	Starting and Stopping the Engine	14
2	Guide to Using this Manual	2	9.1	Selecting the correct starting procedure	14
2.1	Symbols used with warnings in the text	2	9.2	Preparing the engine for start	14
2.2	Symbols in Text	3	9.3	Starting the engine	15
3	Overview	3	9.4	Shut off the engine	16
3.1	Blower	3	10	Checking the Blower	16
3.2	Icons	4	10.1	Checking the controls	16
4	Safety Precautions	5	10.2	Checking the nozzle	16
4.1	Warning Symbols	5	11	Operating the Blower	16
4.2	Intended Use	5	11.1	Holding and Guiding the Blower	16
4.3	Requirements concerning the user	5	11.2	Blowing	17
4.4	Clothing and equipment	6	11.3	Setting to winter mode	17
4.5	Working Area and Surroundings	6	12	After Finishing Work	17
4.6	Safe condition	7	12.1	When Work is Finished	17
4.7	Fuel Mixture and Refueling	7	13	Transporting	17
4.8	Working	8	13.1	Transporting the blower	17
4.9	Transport	9	14	Storing	18
4.10	Storage	9	14.1	Storing the blower	18
4.11	Cleaning, Maintenance and Repair	10	15	Cleaning	18
5	Preparing the Blower for Operation	10	15.1	Cleaning the blower	18
5.1	Preparing the Blower for Operation	10	15.2	Cleaning the Spark Plug	18
6	Assembling the Blower	10	16	Maintenance	19
6.1	Mounting the Control Handle	10	16.1	Maintenance intervals	19
6.2	Mounting the Blower Tube	11	16.2	Adjusting the throttle cable	19
6.3	Attaching the Nozzle	11	17	Repairing	19
7	Adjusting Blower for User	12	17.1	Repairing the Blower	19
7.1	Fitting and Adjusting the Carrying System	12	18	Troubleshooting	20
7.2	Taking off the carrying system	12	18.1	Troubleshooting the Blower	20
7.3	Adjusting the Control Handle	13	18.2	Replacing air filter	21
7.4	Adjusting the Blower Tube	13	18.3	Adjust idle speed	21
8	Mixing the fuel and refuelling the blower	13	19	Specifications	21
8.1	Mixing fuel	13	19.1	Blower STIHL BR 500	21
8.2	Refuelling the blower	13			

STIHL

This instruction manual is protected by copyright. All rights reserved, especially the rights to reproduce, translate and process with electronic systems.

19.2 Blower STIHL BR 550.....	22
19.3 Blower STIHL BR 600.....	22
19.4 Sound Values and Vibration Values	22
19.5 REACH	23
19.6 Exhaust Emissions.....	23
20 Spare Parts and Accessories.....	23
20.1 Spare parts and accessories	23
21 Disposal	23
21.1 Disposing of Blower.....	23
22 EC Declaration of Conformity.....	23
22.1 Blower STIHL BR 500, 550, 600	23

1 Introduction

Dear Customer,

Thank you for choosing STIHL. We develop and manufacture our quality products to meet our customers' requirements. The products are designed for reliability even under extreme conditions.

STIHL also stands for premium service quality. Our dealers guarantee competent advice and instruction as well as comprehensive service support.

STIHL expressly commit themselves to a sustainable and responsible handling of natural resources. This user manual is intended to help you use your STIHL product safely and in an environmentally friendly manner over a long service life.

We thank you for your confidence in us and hope you will enjoy working with your STIHL product.

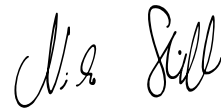

Dr. Nikolas Stihl

IMPORTANT! READ BEFORE USING AND KEEP IN A SAFE PLACE FOR REFERENCE.

2 Guide to Using this Manual

2.1 Symbols used with warnings in the text

WARNING

This symbol indicates dangers that can cause serious injuries or death.

- The measures indicated can avoid serious injuries or death.

NOTICE

This symbol indicates dangers that can cause damage to property.

- ▶ The measures indicated can avoid damage to property.

2.2 Symbols in Text

This symbol refers to a chapter in this instruction manual.

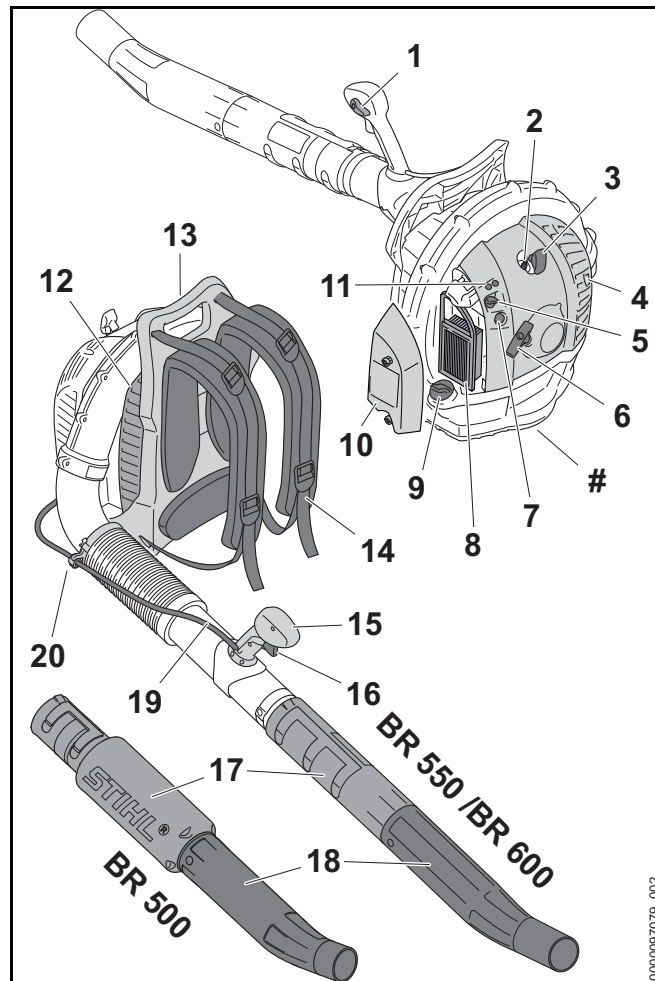
3 Overview**3.1 Blower**

0000097079_002

1 Master control lever

The Master Control Lever is used to operate and stop the engine. The Master Control Lever is used to lock the throttle.

2 Spark plug

Ignites the fuel-air mixture in the engine.

3 Spark plug boot

Connects the ignition lead to the spark plug.

4 Muffler

The muffler reduces the sound emission of the blower.

5 Choke lever

The Choke Lever is used to set the start procedure.

6 Starter grip

Serves to crank the engine.

7 Manual fuel pump

The manual fuel pump eases engine starts.

8 Air filter

The air filter filters the air entering the engine.

9 Fuel Tank Cap

Closes the fuel tank.

10 Filter cover

Covers the air filter.

11 Carburetor adjusting screws

For tuning the carburetor.

12 Shield

The shield protects the user from moving parts inside the blower.

13 Handle

The handle serves to carry the blower.

14 Carrying strap

The carrying strap distributes the weight of the blower over shoulders and back.

15 Control handle

The control handle is used to operate and guide the blower.

16 Throttle trigger

Controls the engine speed.

17 Blower tube

The blower tube directs the air stream.

18 Nozzle

The nozzle directs and controls the air stream.

19 Throttle cable

Connects the throttle trigger to the engine.

20 Throttle cable retainer

The throttle cable retainer secures the throttle cable in position.

Rating plate with machine number**3.2 Icons**

Meanings of symbols that may be on the blower:

**LWA**

Guaranteed sound power level in accordance with Directive 2000/14/EC in dB(A) for the purpose of comparing the sound emissions of products.



This icon denotes the fuel tank.



This symbol denotes the manual fuel pump.



Engine is operated with the slide control in this position.



Engine is stopped when the slide control is in this position.



The engine is started in this position of the gearshift lever.



In this position of the gearshift lever, the engine is prepared for starting.



Shutter is in winter mode in this position.



Shutter is in summer mode in this position.



Do not dispose of the product with domestic waste.



Tie back long hair and confine it so that it cannot be pulled into the blower.



Maintain a safety distance.

4 Safety Precautions

4.1 Warning Symbols

Meanings of warning symbols on the blower:



Observe safety notices and take the necessary precautions.



Read, understand and keep the User Manual.



Wear goggles and hearing protection.



Observe the safety advice concerning flying objects and associated measures.



Avoid inhaling exhaust gas.

4.2 Intended Use

The blower STIHL BR 500, BR 550 and BR 600 is designed for blowing leaves, grass, paper and similar materials.

⚠ WARNING

- Using the blower for purposes for which it is not designed may result in serious or fatal injuries and damage to property.
 - ▶ Always use the blower as described in this Instruction Manual.

4.3 Requirements concerning the user

⚠ WARNING

- Users who have had no instruction cannot recognize or assess the risks involved in using the blower. The user or other persons may sustain serious or fatal injuries.



- ▶ Read, understand and keep the User Manual.

- ▶ If you pass the blower on to another person: Always give them the instruction manual.
- ▶ Make sure that the user meets the following conditions:
 - The user is rested.
 - The user must be in good physical condition and mental health to operate and work with the blower. If the user is able to operate the equipment but has physical, sensory or mental restrictions, the user may

only work with the equipment under the supervision of or after receiving instruction from a responsible person.

- The user is able to recognize and assess the risks involved in using the blower.
 - The user is an adult, or is being trained in an occupation under supervision according to national regulations.
 - The user has received instruction from a STIHL servicing dealer or other expert before operating the blower for the first time.
 - The user is not under the influence of alcohol, medicines or drugs.
- ▶ If you have any doubts, be sure to consult a STIHL dealer.
- The blower's ignition system produces an electromagnetic field. This field may interfere with some pacemakers. This may result in serious or fatal injury to the user.
 - ▶ If the user has a pacemaker: Make sure the pacemaker is not affected.

4.4 Clothing and equipment

⚠ WARNING

- Long hair may be pulled into the blower while working. This may result in serious injury to the user.



- ▶ Tie up and confine long hair above your shoulders so that it cannot be pulled into the blower.

- Objects can be thrown at high speed during operation. This may result in injury to the user.



- ▶ Wear close-fitting safety glasses. Suitable safety glasses tested to standard EN 166 or national standards and bearing the corresponding mark are available to buy.

- ▶ Wear long trousers.

- Noise is generated during operation. Noise can damage your hearing.



- ▶ Wear ear protection.

- Dust can be whipped up during operation. Whipped up dust can damage the respiratory passages and cause allergic reactions.
 - ▶ If dust is generated: Wear a dust respirator mask.
- Unsuitable clothing can snag on wood or scrub and may become caught in the blower. Users not wearing suitable clothing are at risk of serious injury.
 - ▶ Wear close-fitting clothing.
 - ▶ Remove scarves and jewelry.
- Wearing unsuitable footwear may cause the user to slip. This may result in injury to the user.
 - ▶ Wear sturdy, closed-toed footwear with high-grip soles.

4.5 Working Area and Surroundings

⚠ WARNING

- Bystanders, children and animals are not aware of the dangers of the blower and objects being thrown into the air and cannot assess them. This may result in serious injury to bystanders, children and animals and damage to property.



- ▶ Do not allow bystanders, children or animals within 15 meters of the work area.

- ▶ Maintain a clearance of 15 meters from objects.
- ▶ Do not leave the blower unattended.
- ▶ Ensure that children cannot play with the blower.

- Hot exhaust gas is emitted through the muffler while the engine is running. Hot exhaust gas can ignite easily flammable materials and cause a fire.
 - ▶ Keep exhaust gas well away from easily flammable materials.

4.6 Safe condition

The blower is in a safe condition if the following conditions are fulfilled:

- The blower is undamaged.
- The blower is clean.
- There is no fuel leaking from the blower.
- The fuel tank cap is closed.
- The controls function properly and have not been modified.
- The wear limits are not exceeded.
- Original STIHL accessories are fitted.
- The accessories are correctly attached.

WARNING

- If not in safe condition, components may no longer operate correctly, safety devices may be disabled and fuel leakage may occur. This may result in serious or fatal injury to people.
 - ▶ Never use a damaged blower.
 - ▶ If fuel is leaking from the blower: Do not use the blower and contact a STIHL dealer for assistance.
 - ▶ Close the fuel tank cap.
 - ▶ If the blower is dirty: Clean the blower.
 - ▶ If the controls do not function properly: Do not work with the blower.
 - ▶ Fit original STIHL accessories designed for this blower model.
 - ▶ Attach accessories as described in this User Manual or in the User Manual for the accessories.

- ▶ Do not insert objects into the openings in the blower.
- ▶ Replace worn or damaged labels.
- ▶ If you have any doubts, be sure to consult a STIHL dealer.

4.7 Fuel Mixture and Refueling

WARNING

- This blower requires a fuel mixture of gasoline and two-stroke engine oil. Fuel mixture and gasoline are extremely flammable. If fuel mixture or gasoline make contact with open fire or hot objects, they can cause a fire or explosions. Persons may be seriously or fatally injured and property may be damaged.
 - ▶ Protect fuel mixture and gasoline from heat and fire.
 - ▶ Do not spill fuel mixture and gasoline.
 - ▶ If fuel has been spilled: Wipe up fuel with a cloth and do not attempt to start engine until all parts of the blower are dry.
 - ▶ Do not smoke.
 - ▶ Never refuel near a fire.
 - ▶ Shut off the engine and allow it to cool down before refueling.
 - ▶ Start the engine at least 3 meters from the fueling spot, outdoors only.
- Inhaling fuel fumes and gasoline fumes can have toxic effects.
 - ▶ Avoid inhaling fuel fumes or gasoline fumes.
 - ▶ Refuel in a well-ventilated location.

- The blower becomes hot during operation. The fuel expands and excess pressure can build up in the tank. Fuel can escape as a spray when the fuel tank cap is opened. The escaping fuel can ignite. This may result in serious injury to the user.
 - ▶ Allow the blower to cool down first and then open the tank cap carefully.
- Clothing that has been in contact with fuel or gasoline is more easily flammable. Persons may be seriously or fatally injured and property may be damaged.
 - ▶ If your clothing comes into contact with fuel or gasoline: Change your clothing.
- Fuel mix, gasoline and two-stroke engine oil can harm the environment.
 - ▶ Do not spill fuel, gasoline or two-stroke engine oil.
 - ▶ Dispose of fuel mix, gasoline and two-stroke engine oil in accordance with local regulations and environmental requirements.
- Fuel, gasoline or two-stroke engine oil can cause irritation if they come into direct contact with the skin or eyes.
 - ▶ Avoid contact with fuel, gasoline and two-stroke engine oil.
 - ▶ If skin contact occurs: Wash affected areas of skin with plenty of water and soap.
 - ▶ If eye contact occurs: Flush eyes with plenty of water for at least 15 minutes and consult a doctor.
- The blower's ignition system produces sparks. Unconfined sparks may cause a fire or an explosion in an easily combustible or explosive environment. Persons may be seriously or fatally injured and property may be damaged.
 - ▶ Use the spark plugs described in this instruction manual.
 - ▶ Insert and tighten down the spark plug.
 - ▶ Connect the spark plug boot and press it down firmly.

- The blower can be damaged if it is run on a fuel mixture consisting of unsuitable gasoline or an unsuitable two-stroke engine oil or if an incorrect mix ratio of gasoline and two-stroke engine oil is used.
 - ▶ Mix the fuel as described in this instruction manual.
- The mixture of gasoline and two-stroke engine oil can separate if it is stored for a long period. The blower can be damaged if it is used with a fuel mix that has separated.
 - ▶ Before refueling the blower: Thoroughly mix the fuel.
 - ▶ Use a mixture of gasoline and two-stroke engine oil that is not older than 30 days (STIHL MotoMix: 2 years).

4.8 Working

WARNING

- If the engine is not started properly, the user may lose control of the blower. This may result in serious injury to the user.
 - ▶ Start the engine as described in this instruction manual.
- In certain situations, the user may no longer be able to concentrate on their work. This may result in the user stumbling, falling and suffering serious injury.
 - ▶ Keep calm and plan your work.
 - ▶ If light and visibility are poor: Do not work with the blower.
 - ▶ Do not use the blower on your own.
 - ▶ Do not work above shoulder height.
 - ▶ Watch out for obstacles.
 - ▶ Work standing on the ground and keep your balance. If you have to work at a height: Use a mobile elevating work platform or secure scaffolding.
 - ▶ If you start feeling fatigue: Take a break. If you start feeling fatigue: Take a break.
 - ▶ Blow in direction of the wind.

- Exhaust gas is produced when the engine is running. Breathing in exhaust gas can have toxic effects. Breathing in exhaust gas can have toxic effects.
 - ▶ Avoid inhaling exhaust gas.
 - ▶ Operate the blower in a well ventilated location.
 - ▶ In the event of nausea, headache, visual disturbances, problems with hearing or dizziness: Stop work and seek medical advice.
- Objects can be thrown at high speed during operation. This can result in injuries to persons and animals and damage to property.



- ▶ Do not direct air blast towards persons, pets and objects.

- The user's ability to hear and assess noises is restricted when wearing hearing protection with the engine running.
 - ▶ Keep calm and plan your work.
- If the blower starts behaving differently or in an unusual way while operating, the blower may be in an unsafe condition. This may result in serious injury to people and damage to property.
 - ▶ Stop work and consult a STIHL servicing dealer.
- The blower may cause vibrations in operation.
 - ▶ Take breaks.
 - ▶ If signs of a circulatory disturbance occur: Consult a doctor.
- The dust whipped up may cause the blower to be electrostatically charged. In certain conditions (e.g. dry environment) the blower may discharge suddenly and emit sparks. Sparks may cause fires and explosions in

highly flammable or explosive environments. Persons may be seriously or fatally injured and property may be damaged.

- ▶ Do not work in a highly flammable or explosive environment.
- In an emergency, the user may start to panic and forget to take off the carrying system. This may result in serious injury to the user.
 - ▶ Practice taking off the carrying system.

4.9 Transport

⚠ WARNING

- The blower may topple over or move during transport. Persons may be injured or property damaged.
 - ▶ Shut off the engine.
 - ▶ Secure the blower with lashing straps, belts or a net to prevent it turning over and moving.
- The muffler and engine may be hot after a period of operation. There is a risk of burn injuries.
 - ▶ Carry the blower on your back.

4.10 Storage

⚠ WARNING

- Children are not aware of and cannot assess the dangers of a blower. Children may be seriously injured.
 - ▶ Shut off the engine.
 - ▶ Store the blower out of the reach of children.
- Moisture may cause the electrical contacts on the blower and metal components to corrode. The blower may be damaged.
 - ▶ Store the blower in a clean, dry state.

4.11 Cleaning, Maintenance and Repair



⚠ WARNING







- The blower can start up unintentionally if the engine is running during cleaning, maintenance or repair operations. This may result in serious injury to people and damage to property.
 - ▶ Shut off the engine.
 - ▶ Pull off spark plug boot.
- The muffler and engine may be hot after a period of operation. This can result in burn injuries.
 - ▶ Wait until the muffler and engine cool down.
- Harsh detergents, cleaning with a water jet or sharp objects can damage the blower. If the blower is not cleaned as described in this instruction manual, components may no longer function properly or safety devices may be rendered inoperative. They may cause serious injury to persons.
 - ▶ Clean the blower as described in this instruction manual.
- If the blower is not maintained as described in this user manual, components may no longer function properly or safety devices may be rendered inoperative. This may result in serious or fatal injury to people.
 - ▶ Do not attempt to service or repair the blower.
 - ▶ If the blower needs to be serviced or repaired: Contact your STIHL servicing dealer for assistance.

5 Preparing the Blower for Operation

5.1 Preparing the Blower for Operation

The following steps must be performed before commencing work:

- ▶ Make sure the blower is in a safe condition,  4.6.
- ▶ Clean blower,  15.1.
- ▶ Mount the blower tube,  6.2.

- ▶ Mount the control handle,  6.1.
- ▶ Attach nozzle,  6.3.
- ▶ Refuel blower,  8.2.
- ▶ Fit the backpack,  7.1.
- ▶ Adjust the control handle,  7.3.
- ▶ Adjust the blower tube,  7.4.
- ▶ Check the controls,  10.1.
- ▶ If it is not possible to carry out these steps: do not use the blower. Consult a STIHL servicing dealer.

6 Assembling the Blower

6.1 Mounting the Control Handle

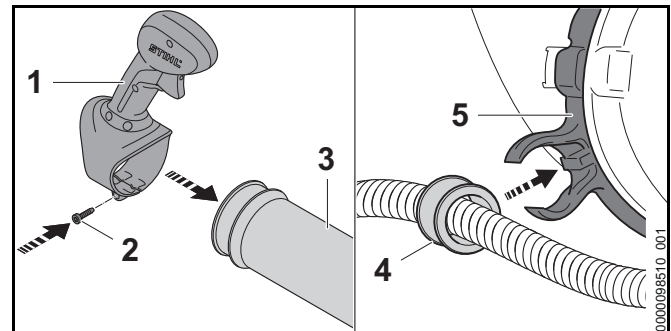

- ▶ Push the control handle (1) onto the blower tube (3).
- ▶ Insert and tighten down the screw (2) firmly.
- ▶ Press the bushing (4) into the throttle cable holder (5). The bushing engages with an audible click.

6.2 Mounting the Blower Tube

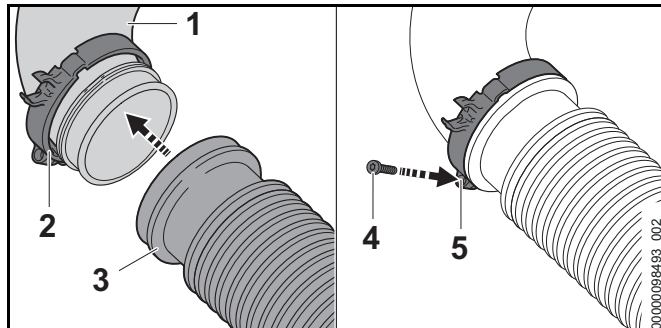

- ▶ Slide "clamp with throttle cable holder" (2) onto the manifold (1).
- ▶ Push the pleated hose (3) onto the elbow (1). The corrugated hose (3) is flush with the manifold (1).
- ▶ Push the "clamp with throttle cable holder (2) onto the pleated hose (3) as far as it will go and align it so that the screw eye (5) points downwards.
- ▶ Insert and tighten down the screw (4) firmly.

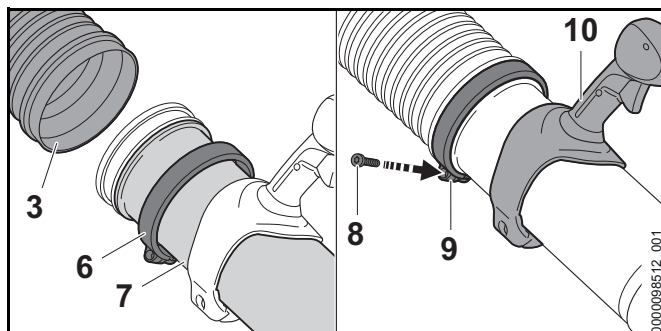

- ▶ Push clamp (6) onto the blower tube (7).
- ▶ Push the blower tube (7) into the corrugated hose (3) as far as it will go.
- ▶ Align the blower tube (7) so that the handle (10) points upwards.
- ▶ Push the clamp (6) onto the pleated hose (3) as far as it will go and align it so that the screw eye (9) points downwards.

- ▶ Insert and tighten down the screw (8) firmly.

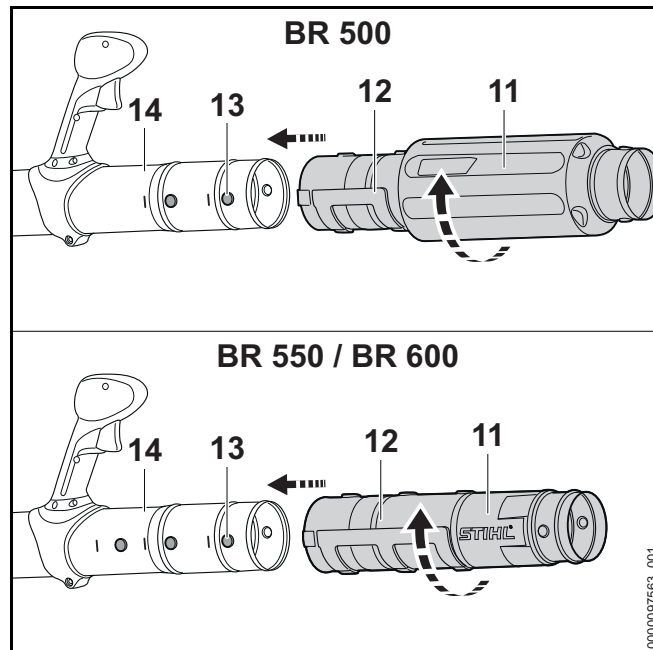

- ▶ Align the peg (13) with the slot (12).
- ▶ Push blower tube (11) into required position on blower tube (14).
- ▶ Rotate blower tube (11) until it engages.

6.3 Attaching the Nozzle

- ▶ Shut off the engine.

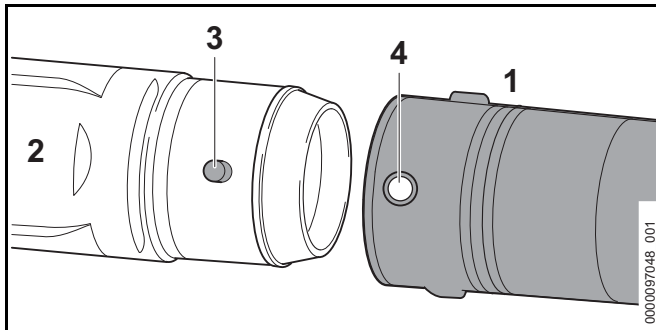

- ▶ Line up the hole (4) and the lug (3).
 - ▶ Push the nozzle (1) onto the blower tube (2).
The nozzle (1) engages.
- The nozzle need not be removed again.

7 Adjusting Blower for User

7.1 Fitting and Adjusting the Carrying System

- ▶ Put the blower on your back.

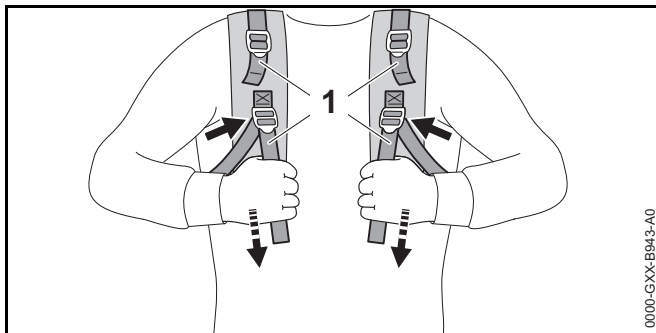

- ▶ Adjust straps (1) until back padding is against your back.

Fitting and Adjusting the Waist Belt

The waist belt is included in the scope of delivery depending on the market.

- ▶ Put the blower on your back.

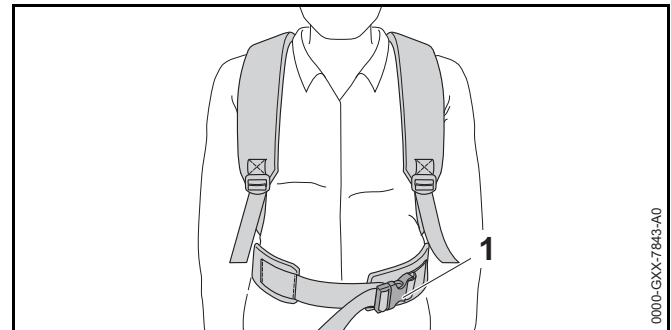

- ▶ Close buckle (1) on the waist belt.

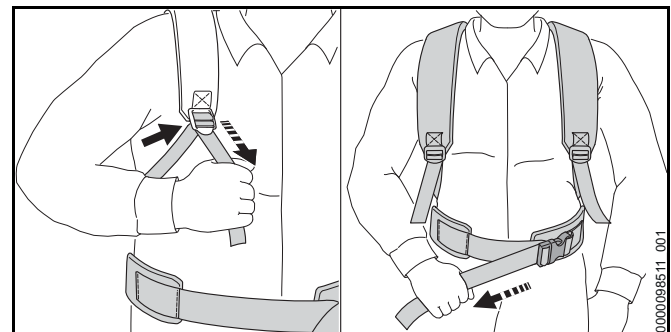

- ▶ Tighten the straps until the waist belt fits snugly on your hips and the back padding is against your back.

7.2 Taking off the carrying system

- ▶ Shut off the engine.
- ▶ Loosen the straps.
- ▶ If available: Open the buckle on the waist belt.
- ▶ Take the blower off your back.

7.3 Adjusting the Control Handle

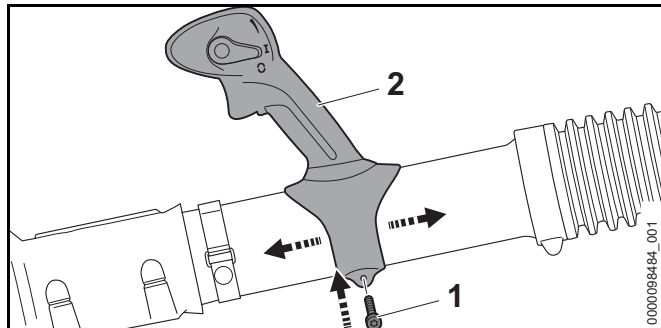

- ▶ Loosen the screw (1).
- ▶ Slide the control handle (2) to the required position.
- ▶ Tighten screw (1) so that the control handle (2) can no longer be turned around the blower tube.

7.4 Adjusting the Blower Tube

The blower can be adjusted in 3 positions depending on the height of the user and the work situation. The positions are marked on the blower tube.

- ▶ Shut off the engine.

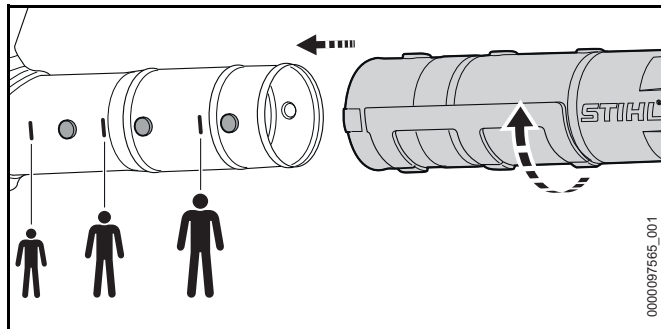

- ▶ Adjust blower tube to the desired position.

8 Mixing the fuel and refuelling the blower

8.1 Mixing fuel

The fuel required for this blower is a mixture of two-stroke engine oil and gasoline in a mixing ratio of 1:50.

STIHL recommends you use STIHL MotoMix.

If you mix the fuel yourself, use only STIHL two-stroke engine oil or another high-performance engine oil in accordance with JASO FB, JASO FC, JASO FD, ISO-L-EGB, ISO-L-EGC or ISO-L-EGD.

STIHL specifies STIHL HP Ultra two-stroke engine oil or an equivalent high-performance engine oil in order to maintain emission limits over the machine's service life.

- ▶ Make sure that the octane number of the gasoline is at least 90 RON and the ethanol content is not more than 10%.
- ▶ Make sure the two-stroke engine oil you are using meets the requirements.
- ▶ Depending on the desired amount of fuel, determine the correct amounts of two-stroke engine oil and gasoline in a mixing ratio of 1:50. Examples for fuel mixes:
 - 20 ml Two-stroke engine oil, 1 l gasoline
 - 60 ml Two-stroke engine oil, 3 l gasoline
 - 100 ml Two-stroke engine oil, 5 l gasoline
- ▶ Pour two-stroke engine oil into a clean approved fuel canister first and then add gasoline.
- ▶ Stir the fuel before topping up.

8.2 Refuelling the blower

- ▶ Shut off the engine.
- ▶ Place the blower on a level surface so that the fuel tank cap faces up.
- ▶ Use a damp cloth to clean the fuel tank cap and the area around it.

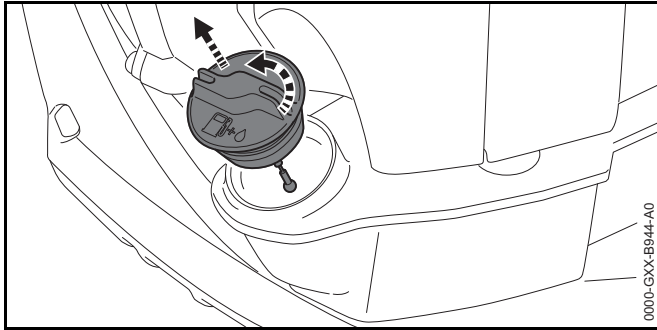

- ▶ Turn the tank cap counterclockwise until it can be removed.
- ▶ Remove the fuel tank cap.

NOTICE

Exposure to light, solar irradiation and extreme temperatures, fuel may accelerate fuel decomposition. The blower can be damaged if it is used with a fuel mix that has become separated.

- ▶ Stir the fuel before topping up.
 - ▶ Do not top up with fuel stored for more than 30 days.
-
- ▶ When topping up, ensure that no fuel is spilled and that the fuel level remains at least 15 mm under the edge of the tank.

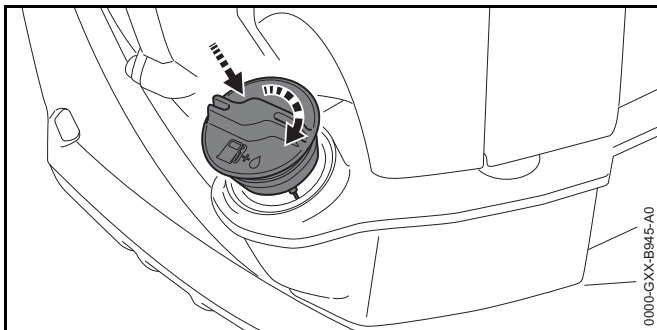

- ▶ Fit the fuel tank cap on the tank opening.

- ▶ Turn the tank cap clockwise and tighten it down firmly by hand.
The fuel tank is closed.

9 Starting and Stopping the Engine

9.1 Selecting the correct starting procedure

When must the engine be prepared for starting?

The engine must be prepared for starting if the following condition is met:

- The engine is at ambient temperature.
- ▶ Prepare engine for start and then start the engine.

When can the engine be started without preparation?

The engine can be started directly if the following condition is met:

- The engine can be started without preparation if it has been running for at least 1 minute and only shut down for a short work break.
 - The engine stopped when accelerated for the first time.
 - The engine stopped because the fuel tank was empty.
- ▶ Start the engine.

9.2 Preparing the engine for start

- ▶ Select the correct starting procedure.
- ▶ Stand the blower on a level surface.

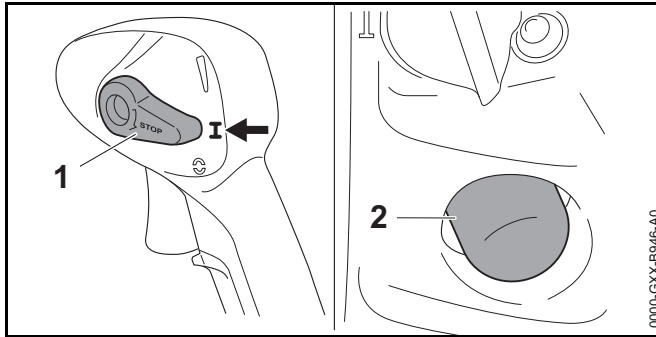

- ▶ Move the Master Control Lever (1) to position **I**.
- ▶ Depress the manual fuel pump (2) at least 6 times.

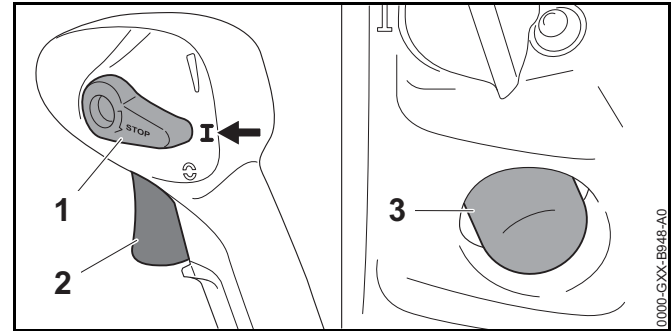

- ▶ Move the Master Control Lever (1) to position **I**.
- ▶ Depress the manual fuel pump (3) at least 6 times.

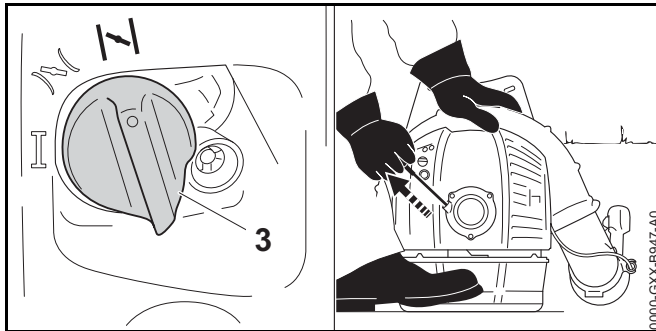

- ▶ Move the choke lever (3) to position **I**.
- ▶ Press the blower onto the ground with the left hand on the motor and step onto the base plate with the right foot.
- ▶ Pull the starter grip slowly with your right hand until you feel it engage.
- ▶ Pull the starter grip quickly and allow the starter rope to rewind several times until the engine fires and stops.

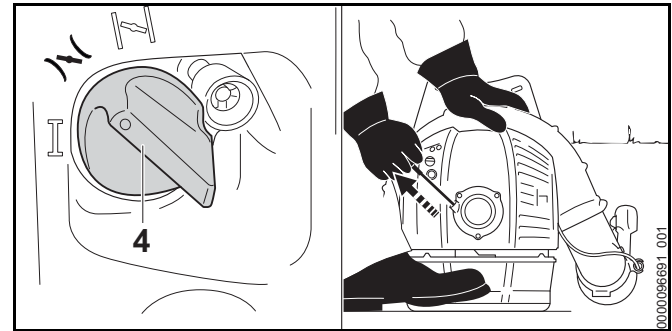



- ▶ Move the choke lever (4) to position **I**.
- ▶ Press the blower onto the ground with the left hand on the motor and step onto the base plate with the right foot.
- ▶ Pull the starter grip slowly with your right hand until you feel it engage.
- ▶ Pull the starter grip quickly and allow the starter rope to rewind several times until the engine runs.
- ▶ Blip the throttle trigger (2).
The choke lever (4) springs to position **I**. The engine runs at idling speed.

9.3 Starting the engine

- ▶ Select the correct starting procedure.
- ▶ Place the blower on a level surface and place the blowpipe on the floor.

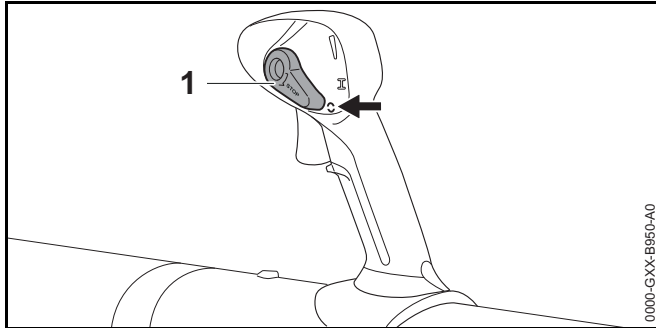
9.4 Shut off the engine



- ▶ Move the Master Control Lever (1) to position . The engine stops and the Master Control lever (1) springs back to position .



If the engine does not stop:

- ▶ Move the choke lever to position . The engine stops.
- ▶ Do not use the blower. Consult a STIHL servicing dealer. The Master Control lever is defective.

10 Checking the Blower

10.1 Checking the controls

Shut off the engine

- ▶ Start the engine.
- ▶ Move the Master Control Lever to position . The engine stops.
- ▶ If the engine does not stop:
 - ▶ Move the choke lever to position . The engine stops.
 - ▶ Do not use the blower. Consult a STIHL servicing dealer. The Master Control lever is defective.

10.2 Checking the nozzle

- ▶ Shut off the engine.

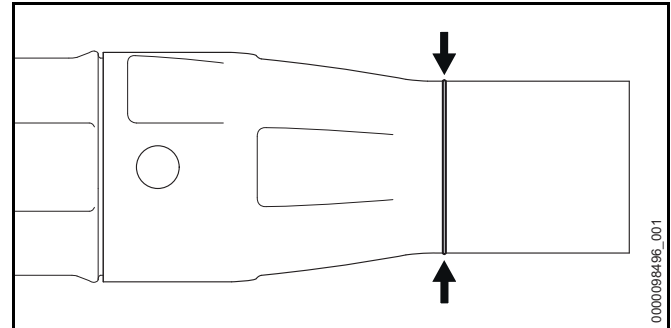

- ▶ Check whether the wear mark on the blower tube is visible.
- ▶ If there is no visible wear mark on the blower tube: Do not use the blower and contact your STIHL dealer for assistance.
- ▶ If you have any doubts, be sure to consult a STIHL dealer.

11 Operating the Blower

11.1 Holding and Guiding the Blower

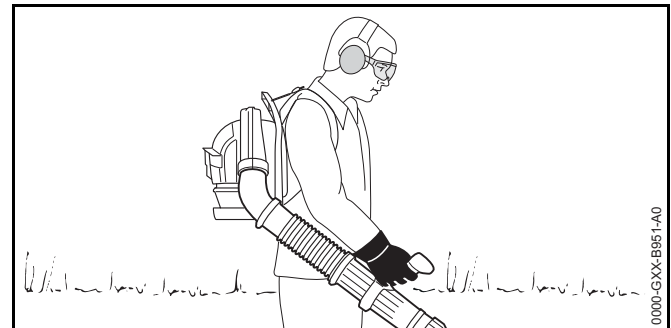

- ▶ Carry the blower on your back.
- ▶ Hold the blower unit by the operating handle with your right hand so that your thumb encloses the control handle.

Carrying the blower

- ▶ Carry the blower on your back and hold the blower by the operating handle with your right hand or carry it by the handle.

Transporting the blower in a vehicle

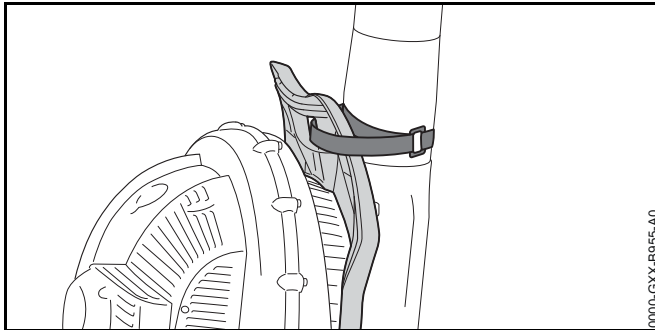

- ▶ Attach the blower to the handle of the back plate using the Velcro strap.
- ▶ Secure the blower in an upright position so that the blower cannot tip over or move.

14 Storing

14.1 Storing the blower

- ▶ Shut off the engine.

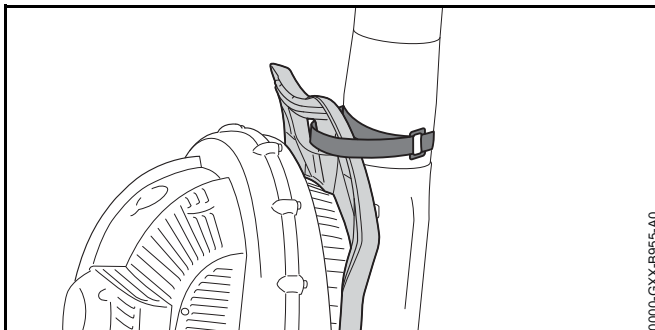

- ▶ Attach the blower to the handle of the back plate using the Velcro strap.
- ▶ The blower should be stored in such a way that the following conditions are fulfilled:
 - Blower must be out of the reach of children.
 - Blower must be clean and dry.

If you store the blower for more than 3 months:

- ▶ Open the fuel tank cap.
- ▶ Drain the fuel tank.
- ▶ Seal fuel tank.
- ▶ Have the fuel tank cleaned by a STIHL dealer.
- ▶ Start the engine and run it at idling speed until it stops.

15 Cleaning

15.1 Cleaning the blower

- ▶ Shut off the engine.
- ▶ Allow the blower to cool down.
- ▶ Clean blower with a damp cloth.
- ▶ Clean vents with a paintbrush.
- ▶ Clean the shield with a paintbrush or soft brush.

15.2 Cleaning the Spark Plug

- ▶ Shut off the engine.
- ▶ Allow the blower to cool down.

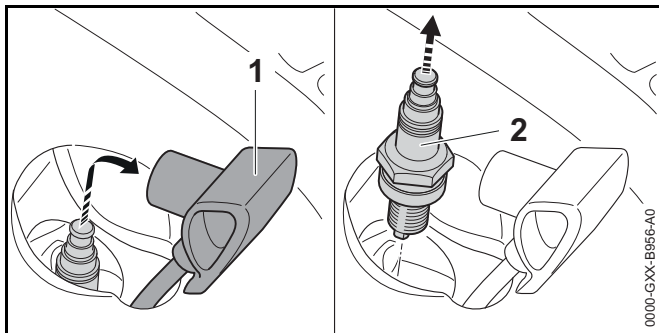

- ▶ Pull off the spark plug boot (1).
- ▶ If the area around the spark plug (2) is soiled: Clean it with a damp cloth (2).
- ▶ Unscrew the spark plug (2).
- ▶ Clean the spark plug (2) with a damp cloth.
- ▶ If the spark plug (2) is corroded: Install a new spark plug (2).
- ▶ Fit the spark plug (2) and tighten it down firmly.
- ▶ Press the spark plug boot (1) firmly home.

16 Maintenance

16.1 Maintenance intervals

Maintenance intervals depend on the ambient conditions and the operating conditions. STIHL recommends the following maintenance intervals:

If engine is low on power or cranking effort is very high

- ▶ Have valve clearance checked and, if necessary, adjusted by a STIHL specialist dealer.

After every 100 hours of operation

- ▶ Replace the spark plug.

After every 150 hours of operation

- ▶ Have the combustion chamber cleaned by a STIHL specialist dealer.

Monthly

- ▶ Have the fuel tank cleaned by a STIHL dealer.
- ▶ Have the pickup body in the fuel tank cleaned by a STIHL dealer.

Annually

- ▶ Have the blower checked by a STIHL servicing dealer.
- ▶ Have the pickup body in the fuel tank replaced by a STIHL dealer.

16.2 Adjusting the throttle cable

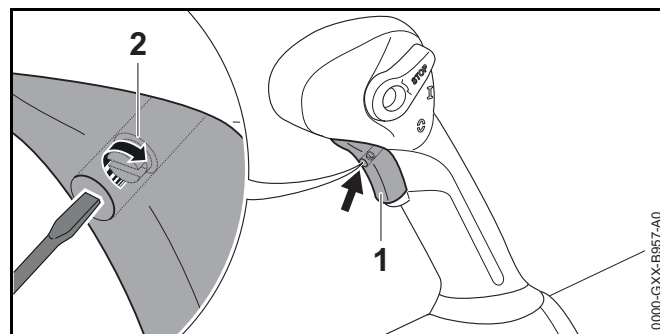

- ▶ Press the throttle trigger (1) and keep pressed.
- ▶ Turn screw (2) clockwise until resistance is felt.
- ▶ Continue turning screw (2) clockwise by half a turn.

17 Repairing

17.1 Repairing the Blower

The blower cannot be repaired by the user.

- ▶ If the blower is damaged: Do not use the blower and contact your STIHL dealer for assistance.

18 Troubleshooting

18.1 Troubleshooting the Blower

Most problems can be attributed to the same cause.

- ▶ Carry out the following measures:
 - ▶ Replace the air filter.
 - ▶ Clean or replace the spark plug.
 - ▶ Adjust saw for winter or summer operation.
 - ▶ Adjust the idle speed.
- ▶ If the problem continues: Carry out the measured listed below.

Fault	Cause	Remedy
The engine does not start.	There is not enough fuel in the fuel tank.	▶ Mix the fuel and refuel the blower.
	The carburetor is too hot.	▶ Allow the blower to cool down. ▶ Depress the manual fuel pump at least 10 times before starting the engine.
	The carburetor has iced up.	▶ Allow the blower to warm up to + 10 °C.
The engine idles erratically.	The carburetor has iced up.	▶ Allow the blower to warm up to + 10 °C.
The engine stops while idling.	The carburetor has iced up.	▶ Allow the blower to warm up to + 10 °C.
The engine does not reach maximum speed.	Throttle cable adjustment is not correct.	▶ Adjust the throttle cable.

18.2 Replacing air filter

The air filter cannot be cleaned. The air filter must be replaced if it is damaged or there is a loss of engine power.

- ▶ Shut off the engine.

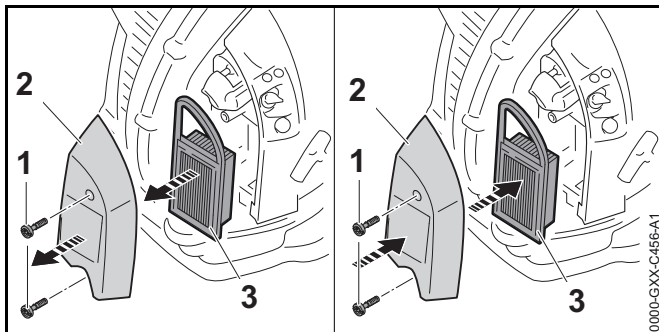

- ▶ Take out the screws (1).
- ▶ Remove filter cover (2).
- ▶ Clean the area around the air filter (3) with a damp cloth or a soft brush.
- ▶ Take out the air filter (3).
- ▶ Insert new air filter (3) and replace filter cover (2).
- ▶ Insert screws (1) and tighten.

18.3 Adjust idle speed

- ▶ Start the engine.
- ▶ Warm up the engine by opening and closing the throttle for about 1 minute.

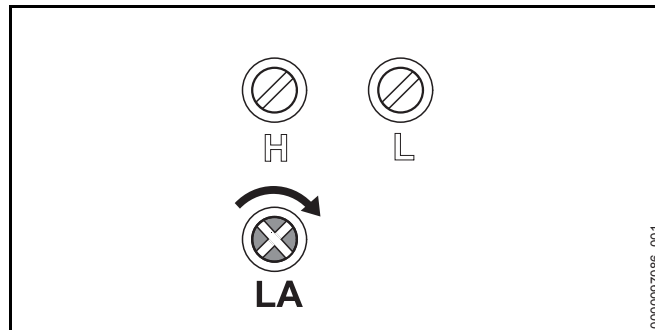

The engine runs unsteadily at idle or stalls

- ▶ Turn the idle speed screw LA slowly clockwise until the engine runs smoothly.

19 Specifications

19.1 Blower STIHL BR 500

- Displacement: 64.8 cm³
- Engine power to ISO 8893: 2 kW (2.7 bhp) at 5,300 rpm
- Idle speed to ISO 11681: 2,500 rpm
- Approved spark plug:
 - NGK CMR6H from STIHL
 - Bosch USR 4AC from STIHL
- Electrode gap of the spark plug: 0.5 mm
- Blowing force: 22 N
- Maximum air velocity: 93 m/s
- Average air velocity: 77 m/s
- Air flow rate: 925 m³/h
- Maximum air flow rate (without blower tube assembly): 1380 m³/h
- Dry weight: 10.4 kg
- Max. fuel tank capacity: 1400 cc (1.4 l)

19.2 Blower STIHL BR 550

- Displacement: 64.8 cm³
- Engine power to ISO 8893: 2.5 kW (3.4 bhp) at 6,000 rpm
- Idle speed to ISO 11681: 2,500 rpm
- Approved spark plug:
 - NGK CMR6H from STIHL
 - Bosch USR 4AC from STIHL
- Electrode gap of the spark plug: 0.5 mm
- Blowing force: 27 N
- Maximum air velocity: 113 m/s
- Average air velocity: 94 m/s
- Air flow rate: 930 m³/h
- Maximum air flow rate (without blower tube assembly): 1490 m³/h
- Dry weight: 10.1 kg
- Max. fuel tank capacity: 1400 cc (1.4 l)

19.3 Blower STIHL BR 600

- Displacement: 64.8 cm³
- Engine power to ISO 8893: 2.8 kW (3.8 bhp) at 7,200 rpm
- Idle speed to ISO 11681: 2,500 rpm
- Approved spark plug:
 - NGK CMR6H from STIHL
 - Bosch USR 4AC from STIHL
- Electrode gap of the spark plug: 0.5 mm
- Blowing force: 32 N
- Maximum air velocity: 106 m/s
- Average air velocity: 89 m/s
- Air flow rate: 1150 m³/h
- Maximum air flow rate (without blower tube assembly): 1720 m³/h
- Dry weight: 10.3 kg

- Max. fuel tank capacity: 1400 cc (1.4 l)

19.4 Sound Values and Vibration Values

The K-value for sound pressure levels is 2 dB(A). K-value for sound power level is 2 dB(A). K-value for vibration level is 2 m/s².

STIHL recommends wearing ear defenders.

BR 500

- Sound pressure level L_{peq} measured according to DIN ISO 22868: 90 dB(A).
- Sound power level L_{weq} measured according to DIN EN ISO 22868: 100 dB(A).
- Vibration level a_{hv} , eq measured according to DIN EN ISO 22867
 - Standard version: Control handle: 1.4 m/s².
 - Version with bike handle: Control handle: 1.6 m/s².
 - Version with Bike Handle: Left handle: 1.9 m/s².

BR 550

- Sound pressure level L_{peq} measured according to DIN ISO 22868: 98 dB(A).
- Sound power level L_{weq} measured according to DIN EN ISO 22868: 108 dB(A).
- Vibration level a_{hv} , eq measured according to DIN EN ISO 22867
 - Standard version: Control handle: 1.6 m/s².
 - Version with bike handle: Control handle: 1.4 m/s².
 - Version with Bike Handle: Left handle: 2.1 m/s².

BR 600

- Sound pressure level L_{peq} measured according to DIN ISO 22868: 100 dB(A)
- Sound power level L_{weq} measured according to DIN EN ISO 22868: 108 dB(A)
- Vibration level a_{hv} , eq measured according to DIN EN ISO 22867

- Standard version: Control handle: 1.8 m/s².
- Version with bike handle: Control handle: 2.5 m/s².
- Version with Bike Handle: Left handle: 2.1 m/s².

For information on compliance with Employers' Vibration Directive 2002/44/EC see www.stihl.com/vib.

19.5 REACH

REACH is an EC regulation and stands for the Registration, Evaluation, Authorisation and Restriction of Chemical substances.

For information on compliance with the REACH regulation see www.stihl.com/reach.

19.6 Exhaust Emissions

The CO₂ value measured in the EU type approval procedure is specified at www.stihl.com/co2.

The measured CO₂ value was determined on a representative engine in accordance with a standardized test procedure under laboratory conditions and does not represent either an explicit or implied guarantee of the performance of a specific engine.

The applicable exhaust emission requirements are fulfilled by the intended usage and maintenance described in this instruction manual. The type approval expires if the engine is modified in any way.

20 Spare Parts and Accessories

20.1 Spare parts and accessories

STIHL  These symbols indicate original STIHL spare parts and original STIHL accessories.

STIHL recommends the use of original STIHL spare parts and accessories.

Despite ongoing market observation, STIHL is unable to judge the reliability, safety and suitability of other manufacturers' spare parts and accessories; accordingly, STIHL cannot warrant for the use of those parts.

Original STIHL spare parts and original STIHL accessories are available from STIHL dealers.

21 Disposal

21.1 Disposing of Blower

Contact your STIHL dealer for information on disposal.

- ▶ Dispose of the blower, water pump, fuel mix, gasoline, two-stroke engine oil, accessories and packaging in accordance with local regulations and environmental requirements.

22 EC Declaration of Conformity

22.1 Blower STIHL BR 500, 550, 600

ANDREAS STIHL AG & Co. KG
Badstraße 115
D-71336 Waiblingen
Germany

declares under our sole responsibility that

- Type: blower
- Manufacturer's brand: STIHL
- Series: BR 500, BR 550, BR 600
- Serial number: 4282

conforms to the relevant provisions of Directives 2011/65/EU, 2006/42/EC, 2014/30/EU and 2000/14/EC and has been developed and manufactured in compliance with the following standards in the versions valid on the date of production: EN ISO 12100, EN 15503, EN 55012, EN 61000-6-1.

The measured and guaranteed equivalent sound power level has been determined in accordance with Directive 2000/14/EC, Annex V.

BR 500

- Measured sound power level: 100 dB(A)
- Guaranteed sound power level: 102 dB(A)

BR 550, BR 600

- Measured sound power level: 108 dB(A)
- Guaranteed sound power level: 110 dB(A)

The technical documents are stored at
ANDREAS STIHL AG & Co. KG Produktzulassung.

The year of construction, the country of manufacture and the machine number are shown on the blower.

Waiblingen, 10.12.2020

ANDREAS STIHL AG & Co. KG

pp

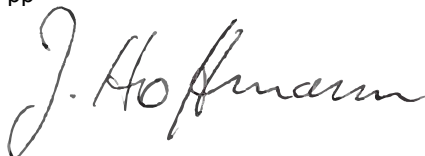
A handwritten signature in black ink, appearing to read 'J. Hoffmann', written in a cursive style.

Dr. Jürgen Hoffmann, Head of Product Data, Regulations
and Licensing

0458-452-0121-H

englisch



www.stihl.com



0458-452-0121-H