

BG 50

STIHL

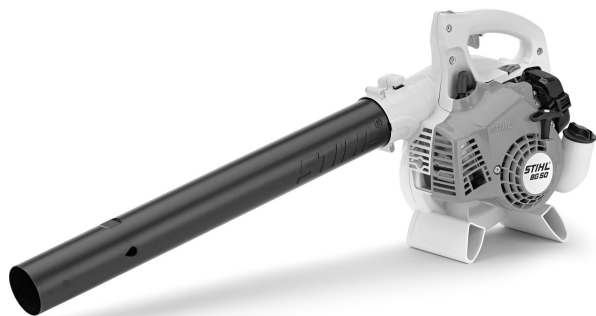

2 - 16 Instruction Manual



Contents

1	Guide to Using this Manual.....	2
2	Safety Precautions and Working Techniques.....	2
3	Assembling the Blower.....	6
4	Fuel.....	6
5	Fueling.....	7
6	Starting / Stopping the Engine.....	8
7	Cleaning the Air Filter.....	9
8	Adjusting the Carburetor.....	10
9	Spark Plug.....	11
10	Engine Running Behavior.....	12
11	Storing the Machine.....	12
12	Maintenance and Care.....	13
13	Main Parts.....	14
14	Specifications.....	14
15	Maintenance and Repairs.....	15
16	Disposal.....	15
17	EC Declaration of Conformity.....	15

1 Guide to Using this Manual

1.1 Pictograms

The meanings of the pictograms attached to the machine are explained in this manual.

Depending on the model concerned, the following pictograms may be attached to your machine.



Fuel tank; fuel mixture of gasoline and engine oil



Operate manual fuel pump

1.2 Symbols in text



WARNING

Warning where there is a risk of an accident or personal injury or serious damage to property.

NOTICE

Caution where there is a risk of damaging the machine or its individual components.

1.3 Engineering improvements

STIHL's philosophy is to continually improve all of its products. For this reason we may modify the design, engineering and appearance of our products periodically.

Therefore, some changes, modifications and improvements may not be covered in this manual.

2 Safety Precautions and Working Techniques



Special safety precautions must be observed when operating a power tool.



It is important you read and understand the User Manual before commissioning and keep it in a safe place for future reference. Non-compliance with the User Manual may cause serious or even fatal injury.

Observe all applicable local safety regulations, e.g. by trade organizations, social insurance institutions, labor safety authorities etc.

If you have not used this machine before: Have your dealer or other experienced user show you how to handle your machine safely or attend a specialist course.

Minors must never work with the machine – except for young people over the age of 16 who are being trained under supervision.

Children, animals and bystanders must remain at a distance.

When the machine is not in use, put it in a place where it does not endanger others. Secure the machine against unauthorized access.

The user is responsible for accidents or risks involving third parties or their property.

Do not pass on or lend the machine to persons who are not familiar with this model and its handling – always include the User Manual.

In some countries the operation of noise emitting power tools is restricted by local regulations. Observe country-specific requirements and regulations.

Do not use a high-pressure washer to clean the power tool. The solid jet of water may damage parts of the unit.

2.1 Accessories and spare parts

Only use parts and accessories that are explicitly approved for this power tool by STIHL or are technically identical. If you have any questions in this respect, consult your dealer. Use only high quality parts and accessories. In order to avoid the risk of accidents and damage to the unit.

STIHL recommends the use of original STIHL parts and accessories. They are specifically designed to match the product and meet your performance requirements.

Never attempt to modify your power tool in any way since this may increase the risk of personal injury. STIHL excludes all liability for personal injury and damage to property caused while using unauthorized attachments.

2.2 Physical fitness

To operate the power tool you must be rested, in good physical condition and mental health. If you have any condition which may be aggravated by strenuous work, check with your doctor before operating a power tool.

If you have a pacemaker: The ignition system of your machine produces an electromagnetic field of very low intensity. This field may interfere with some pacemakers. To reduce health risks, STIHL recommends that persons with pacemakers consult their physician and the pacemaker manufacturer before operating this tool.

Do not operate the power tool if you have consumed alcohol or taken medication, which may impair responsiveness, or taken drugs.

2.3 Intended Use

The blower is designed for blow-sweeping leaves, grass, paper and similar materials, e.g. in gardens, sports stadiums, car parks and driveways. It is also suitable for blow-sweeping forest paths.

The machine must not be used for any other purposes – **risk of accidents!**

Do not operate or store your machine at temperatures below -10 °C – extreme cold may damage machine components.

2.4 Personal Protective Equipment / Personal Protective Clothing

Wear proper protective clothing and equipment.



Clothing must be sturdy but allow complete freedom of movement. Wear close-fitting clothes such as a boiler suit, not a loose jacket.

Avoid wearing any clothing, scarves, neckties or jewelry which could get into the air intake. Tie up and confine long hair above your shoulders.

Wear sturdy shoes with non-slip soles.



WARNING



To reduce the risk of eye injuries, wear close-fitting safety glasses in accordance with European Standard EN 166. Make sure the safety glasses are a snug fit.

Wear "personal" sound protection, e.g. ear defenders.

2.5 Transporting the machine

Always stop the engine.

Transporting in a vehicle:

- Secure the machine against overturning, damage and fuel spillage

2.6 Refueling



Gasoline is extremely flammable – keep it away from naked flames – do not spill any fuel – no smoking.

Always **shut off the engine** before refueling.

Do not fuel a hot engine – **fuel may spill and cause a fire.**

Open the fuel cap carefully to allow any pressure build-up in the tank to release slowly and avoid fuel spillage.

Only refuel the machine in a well ventilated place. If you spill fuel, wipe the machine immediately – if fuel gets on your clothing, change immediately.



Check for fuel leakage! Never start the engine if fuel has been spilled or is leaking – **Fatal burns may result!**



After fueling, tighten down the screw-type fuel cap as securely as possible.

This helps reduce the risk of unit vibrations causing an incorrectly tightened fuel cap to loosen or come off and spill quantities of fuel.

2.7 Before starting

Check that your power tool is properly assembled and in good condition – refer to appropriate chapters in the User Manual:

- Check the fuel system for leaks, especially the visible parts, e. g., fuel cap, hose connections, manual fuel pump (only in machines with a manual fuel pump). In case of leakage and damage, do not start the engine – **risk of fire!**

Have the machine serviced by a dealer before using it

- Throttle trigger must move freely and spring back by itself to the idle position
- Stop switch must move easily to 0
- Check that the spark plug boot is secure – a loose boot may cause sparking that could ignite combustible fumes **and cause a fire!**
- Check condition of blower wheel and blower housing – see chapter on "Using the Blower"
- A worn fan housing (cracks, nicks, chips) may result in an increased risk of injury from thrown foreign objects
- If either the blower wheel or blower housing is damaged, consult your dealer – STIHL recommends you contact a STIHL servicing dealer
- Never attempt to modify the controls or safety devices

To reduce the risk of accidents and personal injury, do not operate your power tool if it is not properly assembled and in good condition

2.8 Starting the engine

Start the engine at least 3 meters from the fueling spot, outdoors only.

Your power tool is designed to be operated by one person only. Do not allow other persons in the work area – even when starting.

Do not drop-start the power tool – start the engine as described in the user manual.

Place the machine on level ground only, ensure that you have a secure footing and hold the machine securely.

As soon as the engine starts, the increasing air flow may eject objects (e.g. stones).

2.9 While working



Do not direct the air blast towards bystanders or animals – the machine may eject small objects at high speed – **risk of injury!**

In the event of impending danger or in an emergency, switch off the engine immediately – move the stop switch to 0.



To reduce the risk of injury from thrown objects, do not allow any other persons within 5 meters of your own position.

Never leave a running machine unattended.

Take special care in slippery and wet conditions, in snow, on ice, on slopes or uneven ground – **Risk of slipping!**

Watch out for obstacles such as tree stumps, roots and ditches which could cause you to **trip or stumble**.

Do not work on a ladder or in unstable locations.

Be particularly alert and cautious when wearing hearing protection because your ability to hear warnings (shouts, alarms, etc.) is restricted.

Take breaks when you start getting tired or feeling fatigue – **risk of accidents!**

Work calmly and carefully – in daylight conditions and only when visibility is good. Proceed with caution, do not put others in danger.

When blow-sweeping (in open terrain and in gardens), look out for small animals to prevent endangering them.

After work, place the machine on a level, non-flammable surface. Do not place the machine near easily flammable materials (e.g. wood chips, bark, dry grass, fuel) – **risk of fire!**



Your power tool produces **toxic exhaust fumes** as soon as the engine is running. These gases may be odorless and invisible and may contain unburned hydrocarbons and benzene. Never run the engine indoors or in poorly ventilated locations, even if your model is equipped with a catalytic converter.

To reduce the risk of **serious or fatal injury from breathing toxic fumes**, ensure proper ventilation when working in trenches, hollows or other confined locations.

Stop work immediately if you start suffering from nausea, headaches, impaired vision (e.g. your field of vision gets smaller), impaired hearing, dizziness, or impaired concentration – these symptoms may possibly be the result of too-high exhaust gas concentration – **Risk of accidents!**

The dust, which is swirled up during operation, may be harmful to health. Wear a dust mask in case of dust formation.

To reduce the risk of fire, do not smoke while operating or standing near your power tool. Combustible fuel vapor may escape from the fuel system.

If the machine was exposed to a load for which it was not designed (e.g. heavy impact or a fall), always check that it is in good condition before continuing work – see also "Before Starting". Check in particular that the fuel system has no leaks and the safety equipment is fully operative.

Do not continue operating the machine if it is damaged. In case of doubt, contact a dealer.

2.10 Using the blower

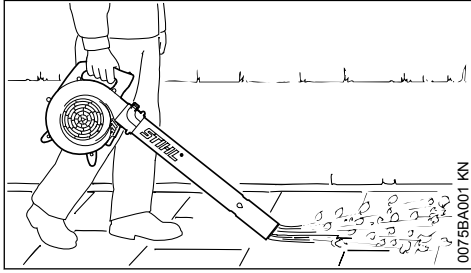

The blower is designed for one-handed operation. The operator must carry the blower with his right hand on the control handle.

Always hold the power tool firmly in your hand.

When blow-sweeping in open terrain and in gardens, look out for small animals.

Work only slowly, moving in a forwards direction – always observe the discharge area of the blower tube – do not move backwards – **risk of tripping!**



WARNING

Operate the machine only with the blower tube completely mounted – **risk of injury!**

2.11 Working Technique

To minimize blowing time, use a rake and broom to loosen dirt particles before you start blowing.

- If necessary, dampen the surface to be cleaned in order to avoid creating too much dust.
- Do not blow particles in the direction of bystanders, in particular in the direction of children, pets, open windows or freshly washed vehicles. Take special care in such situations.
- Remove the blow-swept debris in rubbish bins – do not blow it onto the neighbor's land.
- Operate your power tool at reasonable times only – not early in the morning, late at night or during midday rest periods when people could be disturbed. Observe local rest periods.
- Operate blowers at the lowest engine speed necessary to accomplish the task.
- Check your blower before starting work. Pay special attention to the muffler, air intakes and air filter.

2.12 Vibrations

Prolonged use of the power tool may result in vibration-induced circulation problems in the hands (whitefinger disease).

No general recommendation can be given for the length of usage because it depends on several factors.

The period of usage is prolonged by:

- Hand protection (wearing warm gloves)
- Work breaks

The period of usage is shortened by:

- Any personal tendency to suffer from poor circulation (symptoms: frequently cold fingers, tingling sensations).
- Low outside temperatures.
- The force with which the handles are held (a tight grip restricts circulation).

Continual and regular users should monitor closely the condition of their hands and fingers. If any of the above symptoms appear (e.g. tingling sensation in fingers), seek medical advice.

2.13 Maintenance and Repairs

Service the machine regularly. Do not attempt any maintenance or repair work not described in the instruction manual. Have all other work performed by a servicing dealer.

STIHL recommends that you have servicing and repair work carried out exclusively by an authorized STIHL servicing dealer. STIHL dealers are regularly given the opportunity to attend training courses and are supplied with the necessary technical information.

Only use high-quality replacement parts in order to avoid the risk of accidents and damage to the machine. If you have any questions in this respect, consult a servicing dealer.

STIHL recommends the use of original STIHL replacement parts. They are specifically designed to match your model and meet your performance requirements.

To reduce the risk of injury, **always shut off the engine** before carrying out any maintenance or repairs or cleaning the machine. – Exception: Carburetor and idle speed adjustments.

Do not turn the engine over on the starter with the spark plug boot or spark plug removed unless the slide control / stop switch is on **STOP** or **0** since there is otherwise a **risk of fire** from uncontained sparking.

To reduce the **risk of fire**, do not service or store your machine near open flames.

Check the fuel filler cap for leaks at regular intervals.

Use only a spark plug of the type approved by STIHL and make sure it is in good condition – see "Specifications".

Inspect the ignition lead (insulation in good condition, secure connection).

Check the condition of the muffler.

To reduce the **risk of fire and damage to hearing**, do not operate your machine if the muffler is damaged or missing. –

Do not touch a hot muffler since **burn injury** will result.

3 Assembling the Blower

3.1 Mounting the Blower Tube

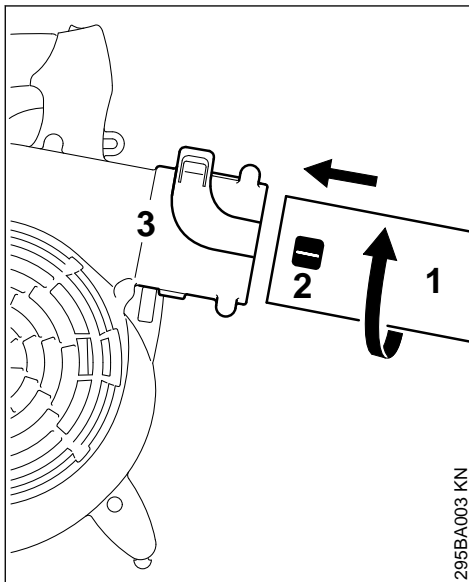

- ▶ Push the blower tube (1) with lug (2) into the fan housing stub (3) and rotate it in the direction of the arrow to lock in position.

3.2 Removing the Blower Tube

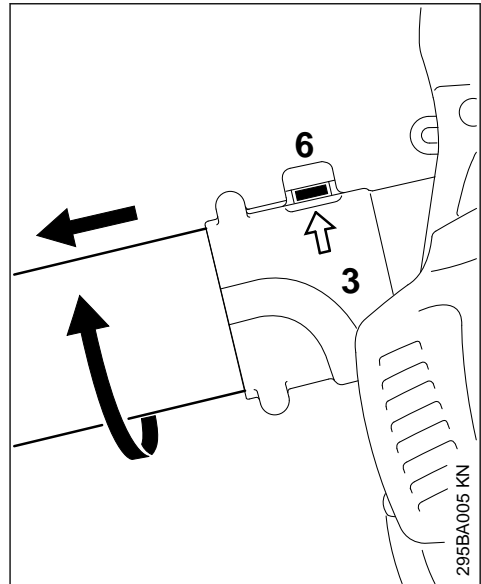

- ▶ Use a suitable tool to lift the tab (6) on the fan housing stub (3).
- ▶ Rotate the blower tube in the direction of the arrow and then pull it out.

4 Fuel

The engine requires a mixture of gasoline and engine oil.

! WARNING

Avoid direct skin contact with fuel and breathing in of gasoline fumes.

4.1 STIHL MotoMix

STIHL recommends using STIHL MotoMix. This pre-blended fuel is free of benzene and lead, is distinguished by a high octane rating, and always provides the proper mixing ratio.

STIHL MotoMix uses STIHL HP Ultra two-stroke engine oil for optimum engine life.

MotoMix is not available in all markets.

4.2 Mixing fuel

NOTICE

Unsuitable fuels or a mixing ratio that deviates from the specification can lead to severe engine damage. The engine, seals, fuel lines and fuel tank may be damaged if low-quality gasoline or engine oil is used.

4.2.1 Gasoline

Use only **high-quality gasoline** with an octane rating of at least 90 ROC – leaded or unleaded.

Gasoline with an alcohol component exceeding 10% can cause impaired engine performance in engines with manually adjustable carburetors and thus should not be used in these engines.

Engines with M-Tronic deliver full engine performance using gasoline with an alcohol component of up to 27% (E27).

4.2.2 Engine oil

If you mix the fuel yourself, use only STIHL two-stroke engine oil or another high-performance engine oil classified as JASO FB, JASO FC, JASO FD, ISO-L-EGB, ISO-L-EGC or ISO-L-EGD.

STIHL specifies STIHL HP Ultra two-stroke engine oil or an equivalent high-performance engine oil in order to maintain emission limits over the machine's service life.

4.2.3 Mixing ratio

with STIHL two-stroke engine oil 1:50; 1:50 = 1 part oil + 50 parts gasoline

4.2.4 Examples

Quantity of gasoline	STIHL two-stroke engine oil 1:50	
Liters	Liters	(ml)
1	0.02	(20)
5	0.10	(100)
10	0.20	(200)
15	0.30	(300)
20	0.40	(400)
25	0.50	(500)

- ▶ Pour oil into an approved safety fuel canister first, then add gasoline and mix thoroughly

4.3 Storing fuel mixture

Store in approved safety fuel canisters only in a dry, cool and secure place protected against light and sunlight.

Fuel mixture deteriorates with age – mix only as much as needed for a few weeks. Do not store fuel mixture for longer than 30 days. The fuel mixture can become unusable more quickly if exposed to light, sunlight or low or high temperatures.

STIHL MotoMix however can be stored for up to 5 years without any problems.

- ▶ Shake the canister containing the fuel mixture thoroughly before refueling

! WARNING

Pressure may have built up in the canister – open it carefully.

- ▶ The fuel tank and the canister in which fuel mixture is stored should be cleaned thoroughly from time to time

Residual fuel and the liquid used for cleaning must be disposed of in accordance with regulations and without harming the environment!

5 Fueling



5.1 Preparations

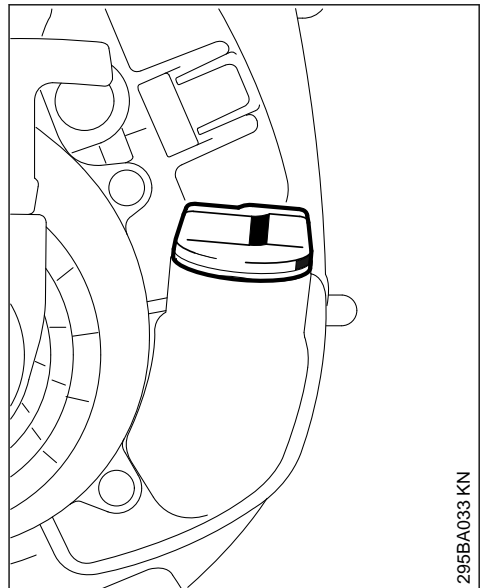

- ▶ Before fueling, clean the filler cap and the area around it to ensure that no dirt falls into the tank.

- Position the machine so that the tank cap faces up.

STIHL recommends you use the STIHL filler nozzle for fuel (special accessory).

5.2 Filling Up with Fuel

Take care not to spill fuel while fueling and do not overfill the tank.

- Open the cap.
- Fill up with fuel.
- Close the cap.



WARNING

After fueling, tighten down the filler cap as securely as possible by hand.

6 Starting / Stopping the Engine

6.1 Starting the Engine

- Observe safety precautions.

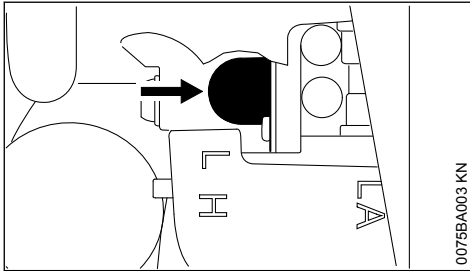

0075BA003 KN

- Press the fuel pump bulb at least five times – even if the bulb is already filled with fuel.

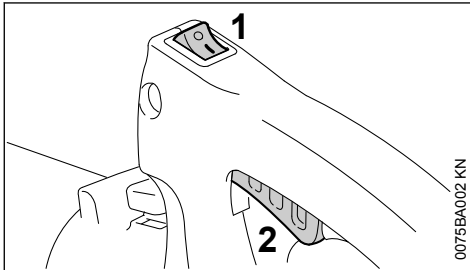

0075BA002 KN

- Move the stop switch (1) to the run position I

Setting the choke lever

If the engine is cold

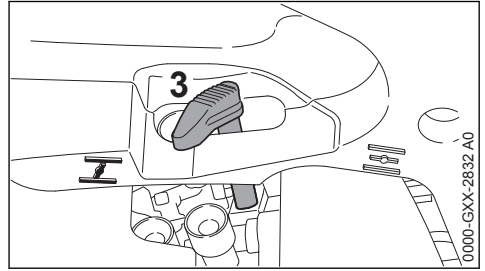

0.000-GXX-2832 A0

- Move the choke lever (3) to **I**
- Pull the throttle trigger (2) and hold it there.
- Crank engine until it begins to fire.
- Move the choke lever (3) to **II**
- Pull the throttle trigger (2) and hold it there.
- Continue cranking until the engine runs.

If the engine is warm

Also use this setting if the engine has been running but is still cold.

- Move the choke lever (3) to **II**
- Pull the throttle trigger (2) and hold it there.
- Continue cranking until the engine runs.

Cranking

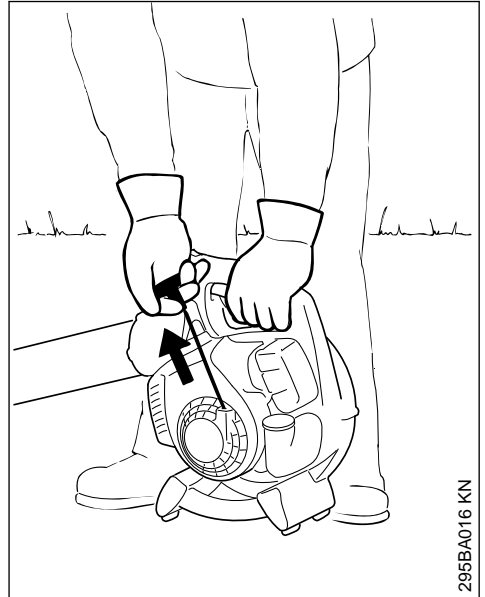

295BA016 KN

- Place the unit on the ground so that it is secure.

- ▶ Make sure you have a firm footing: Hold the unit firmly with your left hand on the housing and press down.
- ▶ Hold the starter grip with your right hand.
- ▶ Pull the starter grip slowly until you feel it engage and then give it a brisk strong pull.

NOTICE

Do not pull out the starter rope all the way – it might otherwise break.

- ▶ Do not let the starter grip snap back. Guide it slowly back into the housing so that the starter rope can rewind properly.

6.2 Stopping the Engine

- ▶ Move the stop switch to 0

6.3 Other Hints on Starting

6.3.1 If the engine stops during warm-up or acceleration

- ▶ Repeat the starting procedure – see "If the engine is cold".

6.3.2 If engine does not start

- ▶ Make sure all settings are correct (choke shutter, stop switch in run position I).
- ▶ Repeat the starting procedure.

6.3.3 If the engine still does not start

- ▶ Move the stop switch to 0
- ▶ Remove the spark plug – see "Spark Plug".
- ▶ Dry the spark plug.
- ▶ Crank the engine several times with the starter to clear the combustion chamber.
- ▶ Refit the spark plug – see "Spark Plug".
- ▶ Move the stop switch to I
- ▶ set the choke lever to $\overline{\text{I}}$ – even if the engine is cold.
- ▶ Pull the throttle trigger (2) and hold it there.
- ▶ Now start the engine.

6.3.4 If fuel tank has been run completely dry and then refueled

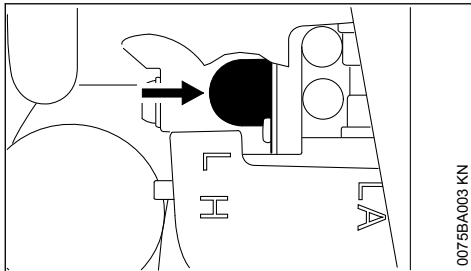

- ▶ Press the fuel pump bulb at least five times – even if the bulb is already filled with fuel.
- ▶ Set the choke lever according to engine temperature.
- ▶ Now start the engine.

7 Cleaning the Air Filter

7.1 If there is a noticeable loss of engine power

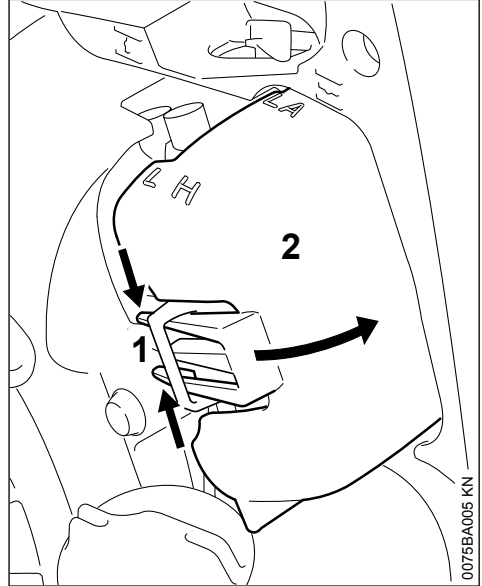

- ▶ Move the choke lever to $\overline{\text{I}}$
- ▶ Squeeze the tabs (1) together.
- ▶ Swing the filter cover (2) open and take it away.
- ▶ Clean away loose dirt from around the filter.

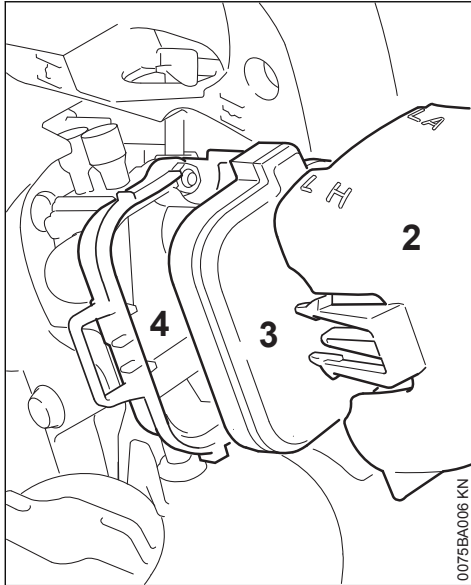

- ▶ Take the filter (3) out of the filter housing (4).
- ▶ Install a new filter. Temporary measure: wash the filter.

Replace any damaged parts.

- ▶ Fit the filter (3) in the filter housing (4).
- ▶ Fit the filter cover (2) so that it snaps into position.

8 Adjusting the Carburetor

8.1 General Information

The carburetor comes from the factory with a standard setting.

This setting provides an optimum fuel-air mixture under most operating conditions.

8.2 Preparations

- ▶ Shut off the engine.
- ▶ Check the air filter and clean or replace if necessary.
- ▶ Check the spark arresting screen (not in all models, country-specific) in the muffler and clean or replace if necessary.

8.3 Standard Setting

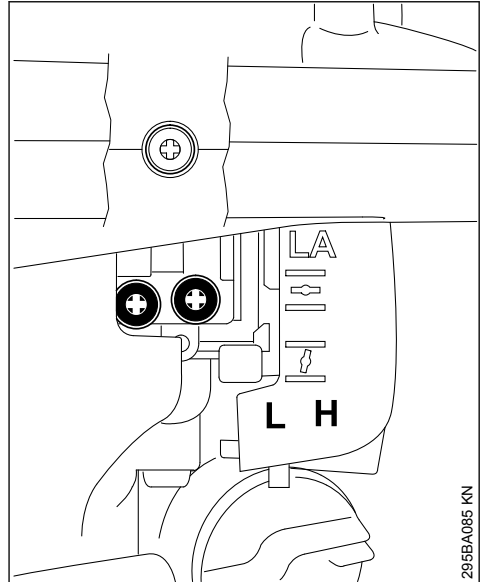

- ▶ Turn high speed screw (H) counterclockwise as far as stop (no more than 3/4 turn).
- ▶ Turn the low speed screw (L) clockwise as far as stop, then turn it back 3/4 turn.

8.4 Adjusting Idle Speed

- ▶ Carry out the standard setting.
- ▶ Start and warm up the engine.

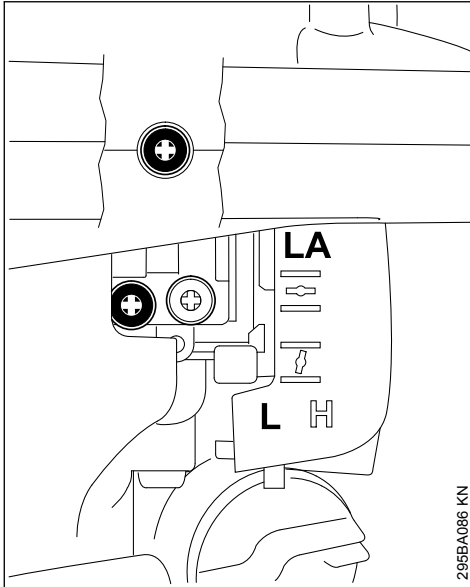

8.4.1 Engine stops while idling

- ▶ Turn the idle speed screw (LA) clockwise until the engine runs smoothly – then back it off a 1/4 turn from that position.

8.4.2 Erratic idling behavior, poor acceleration (despite correction to setting of LA screw).

Idle setting is too lean

- ▶ Turn the low speed screw (L) carefully counterclockwise, no further than stop, until the engine runs smoothly and accelerates well.

8.4.3 Erratic idling behavior, engine speed drops when swinging the machine

Idle setting is too rich

- ▶ Turn the low speed screw (L) slowly clockwise until the engine runs and accelerates smoothly.

It is usually necessary to change the setting of the idle speed screw (LA) after every correction to the low speed screw (L).

8.5 Fine Tuning for Operation at High Altitude

A slight correction of the setting may be necessary if the engine does not run satisfactorily:

- ▶ Carry out the standard setting.
- ▶ Warm up the engine.

- ▶ Turn high speed screw (H) slightly clockwise (leaner) – no further than stop.

NOTICE

After returning from high altitude, reset the carburetor to the standard setting.

If the setting is too lean there is a risk of engine damage due to insufficient lubrication and overheating.

9 Spark Plug

- ▶ If the engine is down on power, difficult to start or runs poorly at idle speed, first check the spark plug.
- ▶ Fit a new spark plug after about 100 operating hours – or sooner if the electrodes are badly eroded. Install only suppressed spark plugs of the type approved by STIHL – see "Specifications".

9.1 Removing the Spark Plug

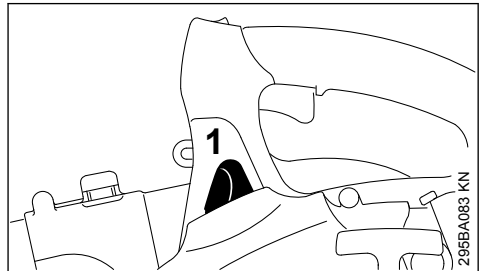

- ▶ Pull off the spark plug boot (1).
- ▶ Unscrew the spark plug.

9.2 Checking the Spark Plug

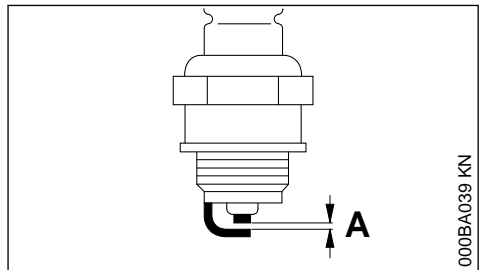

- ▶ Clean dirty spark plug.
- ▶ Check electrode gap (A) and readjust if necessary – see "Specifications".
- ▶ Rectify the problems which have caused fouling of the spark plug.

Possible causes are:

- Too much oil in fuel mix.
- Dirty air filter.
- Unfavorable running conditions.

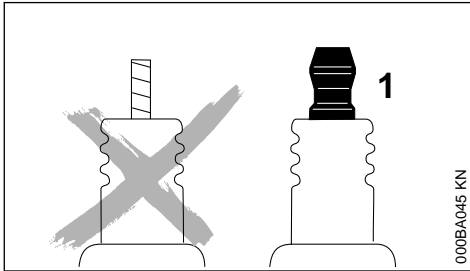

000BA045 KN

**WARNING**

Arcing may occur if the adapter nut (1) is loose or missing. Working in an easily combustible or explosive atmosphere may cause a fire or an explosion. This can result in serious injuries or damage to property.

- ▶ Use resistor type spark plugs with a properly tightened adapter nut.

9.3 Installing the Spark Plug

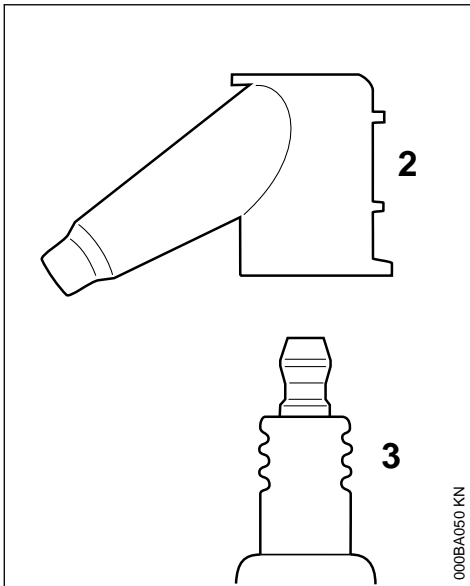

000BA050 KN

- ▶ Screw the spark plug (3) into the cylinder and fit the boot (2) (press it down firmly).

10 Engine Running Behavior

If engine running behavior is unsatisfactory even though the air filter is clean and the carburetor is properly adjusted, the cause may be the muffler.

Have the muffler checked for contamination (carbonization) by your servicing dealer.

STIHL recommends that you have servicing and repair work carried out exclusively by an authorized STIHL servicing dealer.

11 Storing the Machine

If out of use for periods of about 30 days or longer

- ▶ Drain and clean the fuel tank in a well ventilated area.
- ▶ Dispose of fuel properly in accordance with local environmental requirements.
- ▶ If a manual fuel pump is fitted: Press the manual fuel pump at least 5 times.
- ▶ Start the engine and run it at idling speed until it stops
- ▶ Thoroughly clean the machine, especially the cylinder fins and air filter.
- ▶ Store the machine in a dry and safe location. Keep out of the reach of children and other unauthorized persons

12 Maintenance and Care

The following intervals apply to normal operating conditions only. If your daily working time is longer or operating conditions are difficult (very dusty work area, etc.), shorten the specified intervals accordingly.		before starting work	after finishing work or daily	after each refueling stop	weekly	monthly	every 12 months	if problem	if damaged	as required
Complete machine	Visual inspection (condition, wear, leaks)	x		x						
	Clean		x							
Control handle	Check operation	x		x						
Air filter	Clean							x		x
	Replace								x	x
Manual fuel pump	Check	X								
	Have repaired by servicing dealer ¹⁾								X	
Pickup body in fuel tank	Check							x		
	Have replaced by dealer ¹⁾						x		x	x
Fuel tank	Clean							x		x
Carburetor	Check idle setting	x		x						
	Readjust idle									x
Spark plug	Readjust electrode gap							x		
	Replace after 100 operating hours									
Cooling inlets	Clean									x
All accessible screws and nuts (not adjusting screws)	Retighten									x
Safety labels	Replace								x	

¹⁾ STIHL recommends an authorized STIHL servicing dealer.

13 Main Parts

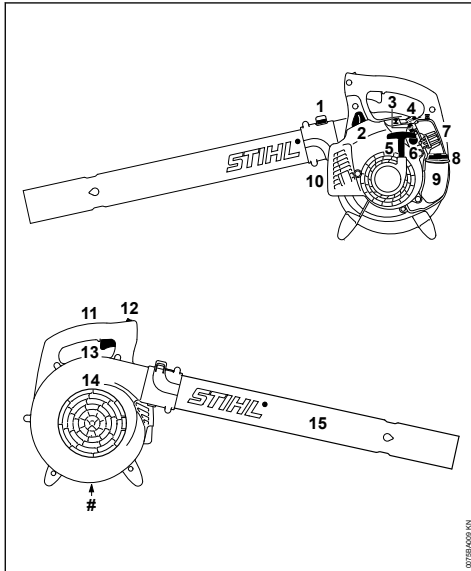

- 1 Tab
- 2 Spark plug boot
- 3 Carburetor adjusting screw
- 4 Choke lever
- 5 Starter grip
- 6 Manual fuel pump
- 7 Filter housing
- 8 Tank cap
- 9 Fuel tank
- 10 Muffler
- 11 Control handle
- 12 Switch
- 13 Throttle trigger
- 14 Intake screen
- 15 Blower tube
- # Serial number

14 Specifications

14.1 Engine

STIHL single cylinder two-stroke engine

Displacement:	27.2 cc
Bore:	34 mm
Stroke:	30 mm
Idle speed:	2,800 rpm

14.2 Ignition System

Electronic magneto ignition

Spark plug (resistor type): Bosch WSR 6 F,
NGK BPMR 7 A

Electrode gap: 0.5 mm

14.3 Fuel System

All position diaphragm carburetor with integral fuel pump

Fuel tank capacity: 430 cc (0.43 l)

14.4 Blowing performance

Blowing force:	13 N
Air velocity:	60 m/s
Air flow rate:	700 m ³ /h
Maximum air velocity:	71 m/s

14.5 Weight

dry: 3.6 kg

14.6 Sound and Vibration Levels

When determining sound and vibration levels, idling and the nominal maximum engine speed are taken into account in a ratio of 1:6.

For further details on compliance with Vibration Directive 2002/44/EC, see

www.stihl.com/vib

14.7 Sound pressure level L_{peq} in accordance with DIN EN 15503

BG 50: 92 dB(A)

14.8 Sound power level L_w in accordance with DIN EN 15503

BG 50: 105 dB(A)

14.9 Vibration level $a_{hv,eq}$ in accordance with DIN EN 15503

Handle, right
BG 50: 10.5 m/s²

The K-factor in accordance with Directive 2006/42/EC is 2.0 dB(A) for the sound pressure level and sound power level; the K-factor in accordance with Directive 2006/42/EC is 2.0 m/s² for the vibration level.

14.10 REACH

REACH is an EC regulation and stands for the Registration, Evaluation, Authorization and Restriction of Chemical substances.

For information on compliance with the REACH regulation (EC) No. 1907/2006 see

www.stihl.com/reach

14.11 Exhaust Emissions

The CO₂ value measured in the EU type approval procedure is specified at

www.stihl.com/co2

in the product-specific technical data.

The measured CO₂ value was determined on a representative engine in accordance with a standardized test procedure under laboratory conditions and does not represent either an explicit or implied guarantee of the performance of a specific engine.

The applicable exhaust emission requirements are fulfilled by the intended usage and maintenance described in this User Manual. The operating license shall be void if the engine is modified in any way.

15 Maintenance and Repairs

Users of this machine may only carry out the maintenance and service work described in this user manual. All other repairs must be carried out by a servicing dealer.

STIHL recommends that you have servicing and repair work carried out exclusively by an authorized STIHL servicing dealer. STIHL dealers are regularly given the opportunity to attend training courses and are supplied with the necessary technical information.

When repairing the machine, only use replacement parts which have been approved by STIHL for this power tool or are technically identical. Only use high-quality replacement parts in order to avoid the risk of accidents and damage to the machine.

STIHL recommends the use of original STIHL replacement parts.

Original STIHL parts can be identified by the STIHL part number, the **STIHL** logo and the STIHL parts symbol  (the symbol may appear alone on small parts).

16 Disposal

Contact the local authorities or your STIHL servicing dealer for information on disposal.

Improper disposal can be harmful to health and pollute the environment.

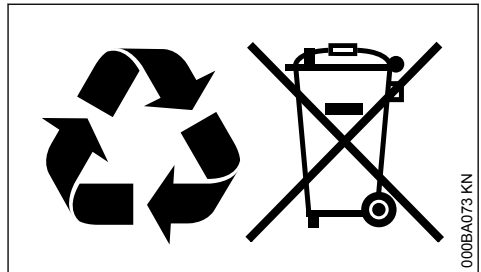

- ▶ Take STIHL products including packaging to a suitable collection point for recycling in accordance with local regulations.
- ▶ Do not dispose with domestic waste.

17 EC Declaration of Conformity

ANDREAS STIHL AG & Co. KG

Badstr. 115

D-71336 Waiblingen

Germany

declares under our sole responsibility that

Designation:	Blower
Make:	STIHL
Series:	BG 50
Serial identification number:	4229
Displacement:	27.2 cm ³

conforms to the relevant provisions of Directives 2011/65/EU, 2006/42/EC, 2014/30/EU and 2000/14/EC and has been developed and manufactured in compliance with the following standards in the versions valid on the date of production:

EN ISO 12100, EN 55012, EN 61000-6-1, EN 15503

The measured and the guaranteed sound power level have been determined in accordance with Directive 2000/14/EC, Annex V, and standard ISO 11094.

Measured sound power level

BG 50: 103 dB(A)

Guaranteed sound power level

BG 50: 105 dB(A)

Technical documents deposited at:

ANDREAS STIHL AG & Co. KG
Produktzulassung

The year of manufacture and serial number are applied to the product.

Done at Waiblingen, 09.07.2020

ANDREAS STIHL AG & Co. KG

pp

A handwritten signature in black ink, appearing to read "J. Hoffmann". The signature is written in a cursive, flowing style.

Dr. Jürgen Hoffmann

Director Product Certification & Regulatory
Affairs

CE

www.stihl.com



0458-425-0121-D



0458-425-0121-D