

STIHL[®]

STIHL FS 38

Instruction Manual



Contents

Guide to Using this Manual	2
Safety Precautions and Working Techniques	2
Approved Combinations of Cutting Attachment, Deflector, Handle and Harness	9
Mounting the Loop Handle	10
Mounting the Deflector	10
Mounting the Cutting Attachment	10
Fuel	14
Fueling	15
Starting / Stopping the Engine	15
Operating Instructions	18
Cleaning the Air Filter	18
Adjusting the Carburetor	19
Spark Plug	21
Engine Running Behavior	22
Rewind Starter	22
Storing the Machine	23
Maintaining the Mowing Head	23
Inspections and Maintenance by Dealer	27
Maintenance and Care	28
Minimize Wear and Avoid Damage	30
Main Parts	31
Specifications	32
Special Accessories	33
Maintenance and Repairs	33
Disposal	34
EC Declaration of Conformity	34

Dear Customer,

Thank you for choosing a quality engineered STIHL product.

It has been built using modern production techniques and comprehensive quality assurance. Every effort has been made to ensure your satisfaction and troublefree use of the product.

Please contact your dealer or our sales company if you have any queries concerning this product.

Your



Dr. Nikolas Stihl

STIHL®

This instruction manual is protected by copyright. All rights reserved, especially the rights to reproduce, translate and process with electronic systems.

Guide to Using this Manual

Pictograms

The meanings of the pictograms attached to the machine are explained in this manual.

Depending on the model concerned, the following pictograms may be attached to your machine.



Fuel tank; fuel mixture of gasoline and engine oil

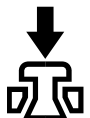

Operate decompression valve



Manual fuel pump

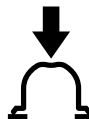

Operate manual fuel pump

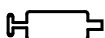

Tube of grease



Intake air: Summer operation



Intake air: Winter operation



Handle heating

Symbols in text



WARNING

Warning where there is a risk of an accident or personal injury or serious damage to property.



NOTICE

Caution where there is a risk of damaging the machine or its individual components.

Engineering improvements

STIHL's philosophy is to continually improve all of its products. For this reason we may modify the design, engineering and appearance of our products periodically.

Therefore, some changes, modifications and improvements may not be covered in this manual.

Safety Precautions and Working Techniques



Some special safety precautions must be observed to reduce the risk of personal injury when operating this power tool because of the very high speed of its cutting attachment.



It is important that you read the instruction manual before first use and keep it in a safe place for future reference. Non-observance of the instruction manual may result in serious or even fatal injury.



Observe all application local safety regulations, standards and ordinances.

If you have not used this type of power tool before: Have your dealer or other experienced user show you how to operate your unit or attend a special course in its operation.

Minors should never be allowed to use a power tool.

Keep bystanders, especially children, and animals away from the work area.

When the power tool is not in use, shut it off so that it does not endanger others. Secure it against unauthorized use.

The user is responsible for avoiding injury to third parties or damage to their property.

Do not lend or rent your power tool without the instruction manual. Be sure that anyone using it understands the information contained in this manual.

The use of noise emitting power tools may be restricted to certain times by national or local regulations.

To operate the power tool you must be rested, in good physical condition and mental health.

If you have any condition that might be aggravated by strenuous work, check with your doctor before operating a power tool.

Persons with pacemakers only: The ignition system of your power tool produces an electromagnetic field of a very low intensity. This field may interfere with some pacemakers. STIHL recommends that persons with pacemakers consult their physician and the pacemaker manufacturer to reduce any health risk.

Do not operate the power tool if you are under the influence of any substance (drugs, alcohol) which might impair vision, dexterity or judgment.

Depending on the cutting attachment fitted, use your trimmer only for cutting grass, wild growth and similar materials.

It must not be used for any other purpose because of the increased risk of accidents and damage to the machine. Never attempt to modify your power tool in any way since this may result in accidents or damage to the machine.

Only use cutting attachments and accessories that are explicitly approved for this power tool model by STIHL or are technically identical. If you have any

questions in this respect, consult a servicing dealer. Use only high quality parts and accessories in order to avoid the risk of accidents and damage to the machine.

STIHL recommends the use of original STIHL replacement parts. They are specifically designed to match the product and meet your performance requirements.

Never attempt to modify your unit in any way since this may increase the risk of personal injury. STIHL excludes all liability for personal injury and damage to property caused while using unauthorized attachments.

Do not use a pressure washer to clean the unit. The solid jet of water may damage parts of the unit.

The deflector on this power tool cannot protect the operator from all objects thrown by the cutting attachment (stones, glass, wire, etc.). Such objects may ricochet and then hit the operator.

Clothing and Equipment

Wear proper protective clothing and equipment.



Clothing must be sturdy but allow complete freedom of movement. Wear snug-fitting clothing, an overall and jacket combination, do not wear a work coat.



Avoid clothing that could get caught on branches or brush or moving parts of the machine. Do not wear a scarf, necktie or jewelry. Tie up and confine long hair (e.g. with a hair net, cap, hard hat, etc.).



Wear sturdy shoes with non-slip soles.



To reduce the risk of injury from thrown objects, always wear a face shield and safety glasses.

A face shield alone does not provide adequate eye protection.

Wear hearing protection, e.g. earplugs or ear muffs.



Wear heavy-duty gloves.

STIHL offers a comprehensive range of personal protective clothing and equipment.

Transporting the Power Tool

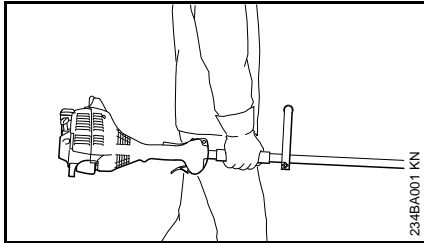

Always turn off the engine.

Carry the unit properly balanced by the drive tube or loop handle.

In vehicles: Properly secure your power tool to prevent turnover, fuel spillage and damage.

Fueling



Gasoline is an extremely flammable fuel. Keep clear of naked flames. Do not spill any fuel – do not smoke.

Always shut off the engine before refueling.

Do not fuel a hot engine – **fuel may spill and cause a fire.**

Open the fuel cap carefully to allow any pressure build-up in the tank to release slowly and avoid fuel spillage.

Fuel your power tool only in well-ventilated areas. If you spill fuel, wipe the machine immediately – if fuel gets on your clothing, change immediately.

Your power tool comes standard with either a screw-type or bayonet-type fuel cap.



After fueling, tighten down the screw-type fuel cap as securely as possible.



Insert the fuel cap with hinged grip (bayonet-type cap) correctly in the opening, turn it clockwise as far as stop and fold the grip down.

This reduces the risk of unit vibrations causing the fuel cap to loosen or come off and spill quantities of fuel.

To reduce the risk of serious or fatal burn injuries, check for fuel leakage. If fuel leakage is found, do not start or run the engine until leak is fixed.

Before Starting

Check that your power tool is properly assembled and in good condition – refer to appropriate chapters in the instruction manual.

- Use only an approved combination of cutting attachment, deflector, handle and harness. All parts must be assembled properly and securely. To reduce the risk of injury, **never** use metal cutting attachments.
- Slide control / stop switch must move easily to **STOP** or **0**.
- Smooth action of throttle trigger lockout (if fitted) and throttle trigger – the throttle trigger must return automatically to the idle position.

- Check that the spark plug boot is secure – a loose boot may cause arcing that could ignite combustible fumes **and cause a fire.**
- Check cutting attachment for correct and secure assembly and good condition.
- Check protective devices (e.g. deflector for cutting attachment) for damage or wear. Always replace damaged parts. Never operate the unit with a damaged deflector.
- Never attempt to modify the controls or safety devices in any way.
- Keep the handles dry and clean – free from oil and dirt – for safe control of the power tool.
- Adjust the harness and handle(s) to suit your height and reach.

To reduce the risk of personal injury, do not operate your power tool if it is damaged or not properly assembled.

If you use a shoulder strap or full harness: Practice removing and putting down the power tool as you would in an emergency. To avoid damage, do not throw the machine to the ground when practicing.

Start the engine.

Start the engine at least 3 meters from the fueling spot, outdoors only.

Place the unit on firm ground in an open area. Make sure you have good balance and secure footing. Hold the unit securely. The cutting attachment must be clear of the ground and all other obstructions because it may begin to run when the engine starts.

Your power tool is a one-person unit. **To reduce the risk of injury** from thrown objects, do not allow other persons within a radius of 15 meters of your own position – even when starting.



To reduce the risk of injury, avoid contact with the cutting attachment.

Do not drop start the power tool – start the engine as described in the instruction manual.



Note that the cutting attachment continues to run for a short period after you let go of the throttle trigger – **flywheel effect**.

Check idle speed setting: The cutting attachment must not rotate when the engine is idling with the throttle trigger released.

To reduce the risk of fire, keep hot exhaust gases and hot muffler away from easily combustible materials (e.g. wood chips, bark, dry grass, fuel).

Holding and Controlling the Unit

Always hold the power tool firmly with both hands on the handles.

Make sure you always have good balance and secure footing.

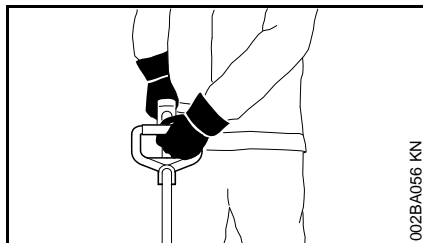

Left hand on loop handle, right hand on control handle, even if you are left-handed.

During Operation

In the event of impending danger or in an emergency, switch off the engine immediately by moving the slide control / stop switch to **STOP** or **0**.

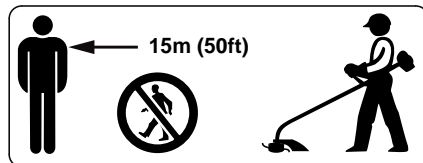

The cutting attachment may catch and fling objects a great distance and cause injury - therefore, do not allow any other persons within a radius of 15 meters of your own position. **To reduce the risk of damage to property**, also maintain this distance from other objects (vehicles, windows). Even maintaining a distance of 15 meters or more cannot exclude the potential danger.

The correct engine idle speed is important to ensure that the cutting attachment stops rotating when you let go of the throttle trigger.

Check and correct the idle speed setting regularly. If the cutting attachment continues to rotate when the engine is idling, have the machine checked by your servicing dealer.

Take special care in slippery conditions, on slopes or uneven ground.

Watch out for obstacles: Roots, tree stumps or holes which **could cause you to trip or stumble**.

Make sure you always have good balance and secure footing.

Always stand on the ground while working, never on a ladder, work platform or any other insecure support.

Be particularly alert and cautious when wearing hearing protection because your ability to hear warnings (shouts, alarms, etc.) is restricted.

To reduce the risk of accidents, take a break in good time to avoid tiredness or exhaustion.

Work calmly and carefully – in daylight conditions and only when visibility is good. Stay alert so as not to endanger others.



Your power tool produces toxic exhaust fumes as soon as the engine is running. These fumes may be colorless and odorless and contain unburned hydrocarbons and benzol. Never run the engine indoors or in poorly ventilated locations, even if your model is equipped with a catalytic converter.

Ensure proper ventilation when working in trenches, hollows or other confined locations. **This reduces the risk of serious or fatal injury from breathing toxic fumes.**

To reduce the risk of accidents, stop work immediately in the event of nausea, headache, visual disturbances (e.g. reduced field of vision), problems with hearing, dizziness, deterioration in ability to concentrate. Apart from other possibilities, these symptoms may be caused by an excessively high concentration of exhaust gases in the work area.

Operate your power tool so that it produces a minimum of noise and emissions – do not run the engine unnecessarily, accelerate the engine only when working.

To reduce the risk of fire, do not smoke while operating or standing near your power tool. Note that combustible fuel vapor may escape from the fuel system.

The dusts, vapor and smoke produced during operation may be dangerous to health. If the work area is very dusty or smoky, wear a respirator.

If your power tool is subjected to unusually high loads for which it was not designed (e.g. heavy impact or a fall), always check that it is in good condition before continuing work – see also "Before Starting".

Check the fuel system in particular for leaks and make sure the safety devices are working properly. Do not continue operating your power tool if it is damaged. In case of doubt, have the unit checked by your servicing dealer.

Do not operate your power tool in the starting throttle position – engine speed cannot be controlled in this position.



To reduce the risk of injury from thrown objects, never operate the power tool without the proper deflector for the type of cutting attachment being used.



Inspect the work area: Stones, pieces of metal or other solid objects may be thrown more than 15 meters and **cause personal injury** or damage the cutting attachment and property (e.g. parked vehicles, windows).



Special care must be taken when working in difficult, over-grown terrain.

When cutting high scrub, under bushes and hedges: Keep cutting attachment at a minimum height of 15 cm to avoid harming small animals.

Before leaving the power tool unattended: Shut off the engine.

Check the cutting attachment at regular short intervals during operation or immediately if there is a noticeable change in cutting behavior:

- Turn off the engine. Hold the unit firmly and press the cutting attachment into the ground to bring it to a standstill.
- Check condition and tightness, look for cracks.
- Replace damaged cutting attachments immediately, even if they have only superficial cracks.

Clean grass and plant residue off the cutting attachment mounting at regular intervals – remove any build up of material from the cutting attachment and deflector.

To reduce the risk of injury, shut off the engine before replacing the cutting attachment.

Do not continue using or attempt to repair damaged or cracked cutting attachments by welding, straightening or modifying the shape (out of balance).

This may cause parts of the cutting attachment to come off and hit the operator or bystanders at high speed and **result in serious or fatal injuries.**

When using mowing heads

Use only the deflector with properly mounted line limiting blade to ensure the mowing lines are automatically trimmed to the approved length.

To reduce the risk of injury, always turn off the engine before adjusting the nylon line of manually adjustable mowing heads

Using the unit with over-long nylon cutting lines reduces the motor's operating speed. The clutch then slips continuously and this causes overheating and damage to important components (e.g. clutch, polymer housing components) – **and this can increase the risk of injury** from the cutting attachment rotating while the engine is idling.

Vibrations

Prolonged use of the power tool may result in vibration-induced circulation problems in the hands (whitefinger disease).

No general recommendation can be given for the length of usage because it depends on several factors.

The period of usage is prolonged by:

- Hand protection (wearing warm gloves)
- Work breaks

The period of usage is shortened by:

- Any personal tendency to suffer from poor circulation (symptoms: frequently cold fingers, tingling sensations).
- Low outside temperatures.
- The force with which the handles are held (a tight grip restricts circulation).

Continual and regular users should monitor closely the condition of their hands and fingers. If any of the above symptoms appear (e.g. tingling sensation in fingers), seek medical advice.

Maintenance and Repairs

Service the machine regularly. Do not attempt any maintenance or repair work not described in the instruction manual. Have all other work performed by a servicing dealer.

STIHL recommends that you have servicing and repair work carried out exclusively by an authorized STIHL servicing dealer. STIHL dealers are regularly given the opportunity to attend training courses and are supplied with the necessary technical information.

Only use high-quality replacement parts in order to avoid the risk of accidents and damage to the machine. If you have any questions in this respect, consult a servicing dealer.

STIHL recommends the use of original STIHL replacement parts. They are specifically designed to match your model and meet your performance requirements.

To reduce the risk of injury, **always shut off the engine** before carrying out any maintenance or repairs or cleaning the machine. – Exception: Carburetor and idle speed adjustments.

Do not turn the engine over on the starter with the spark plug boot or spark plug removed unless the slide control / stop switch is on **STOP** or **0** since there is otherwise a **risk of fire** from uncontained sparking.

To reduce the **risk of fire**, do not service or store your machine near open flames.

Check the fuel filler cap for leaks at regular intervals.

Use only a spark plug of the type approved by STIHL and make sure it is in good condition – see "Specifications".

Inspect the ignition lead (insulation in good condition, secure connection).

Check the condition of the muffler.

To reduce the **risk of fire and damage to hearing**, do not operate your machine if the muffler is damaged or missing. –

Do not touch a hot muffler since **burn injury** will result.

Cutting Attachments and Deflectors

For safety reasons only the combinations of cutting attachment, deflector, handle and shoulder strap approved in the model-specific instruction manual may be used.

Only mowing heads may be used on trimmers with a curved drive tube and loop handle.

Symbols on Deflectors

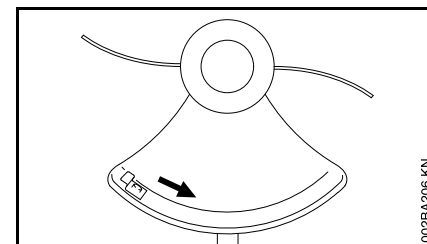

An arrow shows the direction of rotation of the cutting attachments.

Mowing Head with Nylon Lines

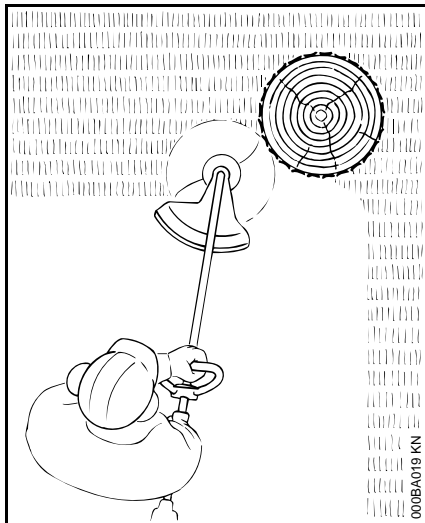

Nylon line achieves a soft cut for edging and trimming around fence posts, trees, etc. – less risk of damaging tree bark.

! WARNING

To reduce the **risk of injury**, **never** use steel wire in place of the nylon cutting line.

STIHL FixCut

Check the wear limit marks!

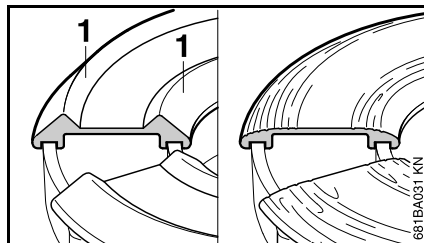

- If the raised moldings (1) on the base of the attachment are worn as shown in the illustration (above right), do not continue using the mowing head. Install a new one. There is otherwise a **risk of injury** from thrown parts of the head.

STIHL PolyCut 6-3 Mowing Head with Polymer Blades

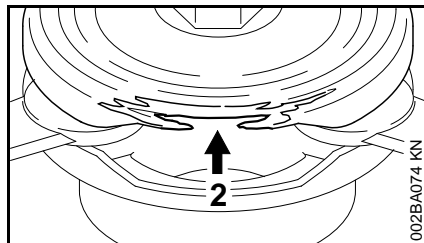
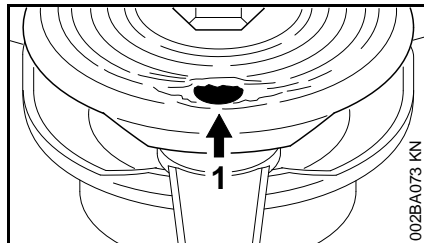

For mowing unobstructed edges of meadows (without posts, fences, trees or similar obstacles).

It is important to follow the maintenance instructions for the Polycut mowing head.

Check the wear limit marks!

Wear limit marks are integrated in the base of the PolyCut.

Do not continue using the PolyCut 6-3 if one of the circular holes (1; arrow) becomes visible or if the projecting rim (2; arrow) has worn away. Install a new mowing head.

! WARNING

If the wear limit marks are ignored, there is a risk of the cutting tool shattering and flying parts injuring the operator or bystanders.

To reduce the risk of accidents from shattered blades, avoid contact with stones, metal and similar solid objects.

Check PolyCut blades for cracks at regular intervals. If a crack is found in one of the blades, always replace **all** the blades.

Approved Combinations of Cutting Attachment, Deflector, Handle and Harness

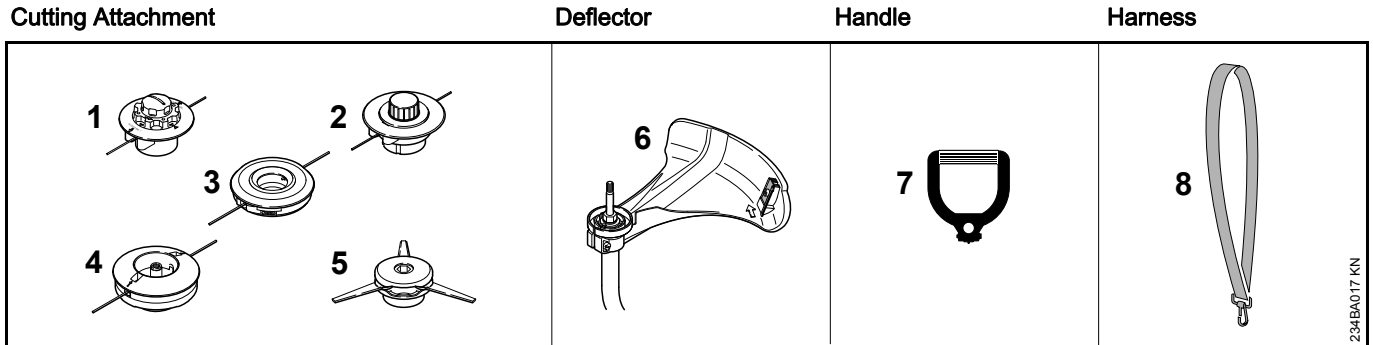

2345BA017 KN

Approved Combinations

Select correct combination from the table according to the cutting attachment you intend to use.

! WARNING

For safety reasons no other combinations are permitted – **risk of accidents.**

Cutting Attachments

Mowing heads

- 1 STIHL AutoCut C 52
- 2 STIHL AutoCut 5-2
- 3 STIHL FixCut 5-2
- 4 STIHL DuroCut 5-2
- 5 STIHL PolyCut 6-3

Deflector

- 6 Deflector with blade for mowing heads

Handle

- 7 Loop handle

Harness

- 8 Shoulder strap may be used

Mounting the Loop Handle

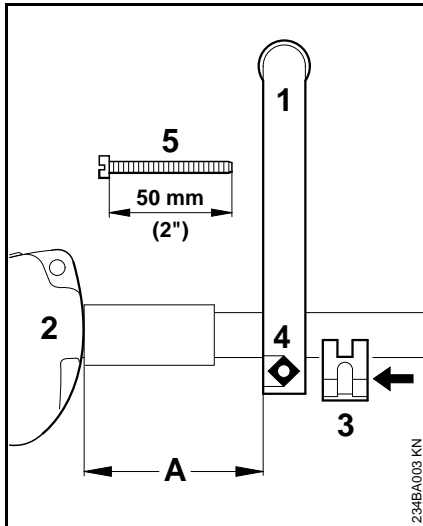

- Fit the loop handle (1) on the drive tube about 15 cm (6") (A) forward of the control handle (2).
- Place the clamp (3) against the drive tube and push it into the loop handle.
- Place the square nut (4) in the loop handle,
- insert the screw (5) from the other side and tighten it down firmly.

Adjusting loop handle to most comfortable position

- Loosen the screw (5).
- Move the loop handle along the drive tube as required.
- Tighten down the screw (5) firmly.

Mounting the Deflector

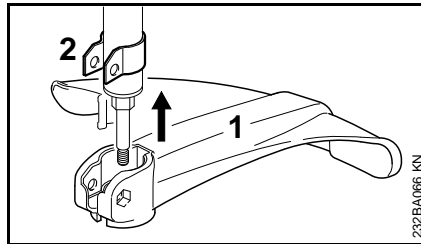

- Push the deflector (1) over the clamp (2) as far as stop.

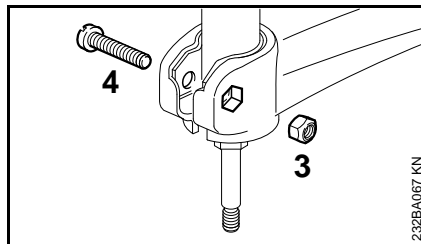

- Insert the nut (3) in the hex recess in the deflector – make sure the holes line up.
- Insert the screw (4) and tighten it down firmly.

Mounting the Cutting Attachment

Placing power tool on the ground

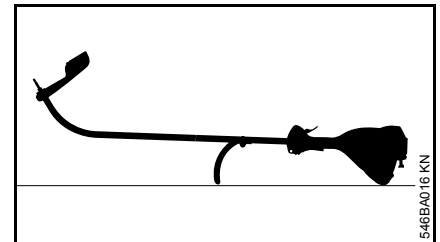

- Switch off the engine.
- Lay your trimmer on its back with the loop handle and shroud pointing down and the output shaft facing up.

Thrust plate

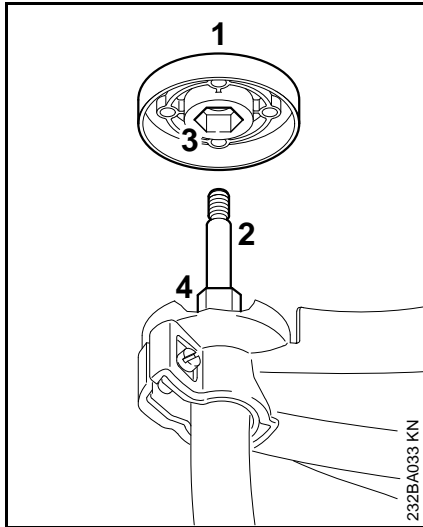

The thrust plate is shipped with the PolyCut 6-3 and FixCut 5-2. It is only required for these mowing heads.

STIHL AutoCut 5-2 mowing head, STIHL AutoCut C 5-2 mowing head

- Pull the thrust plate (1), if fitted, off the shaft (2).

STIHL PolyCut 6-3 mowing head, STIHL FixCut 5-2 mowing head

- Slip the thrust plate (1) over the shaft (2) and engage the hex recess (3) on the external hexagon (4).

Block the shaft.

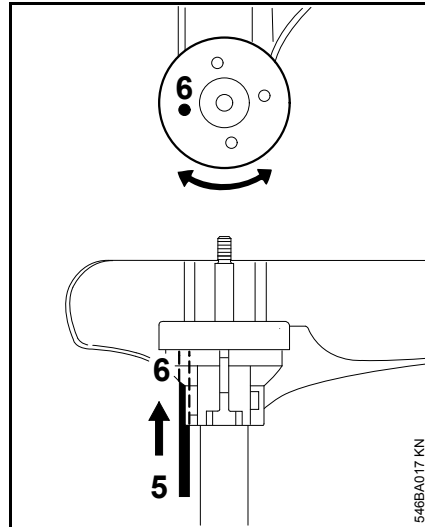

- To block the shaft, insert a suitable tool (5) through the holes (6) in the deflector and thrust plate – turn the thrust plate back and forth if necessary.

Fitting Mowing Head with Screw Mounting

Keep the instruction leaflet for the mowing head in a safe place.

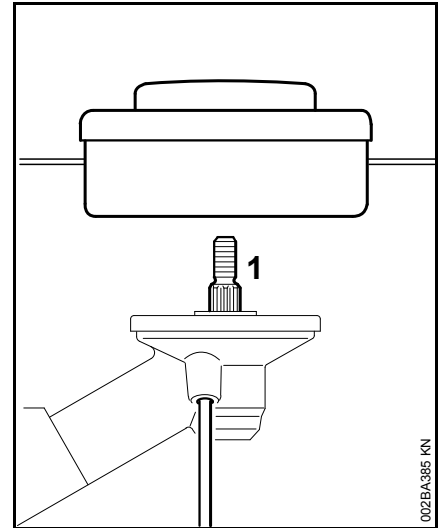

- Screw the mowing head counterclockwise on to the shaft (1) as far as stop.
- Block the shaft.
- Tighten down the mowing head firmly.



NOTICE

Remove the tool used to block the shaft.

Removing the Mowing Head

- Block the shaft.
- Unscrew the mowing head clockwise.

Fitting Mowing Head without Screw Mounting

Keep the instruction leaflet for the mowing head in a safe place.

STIHL AutoCut 5-2

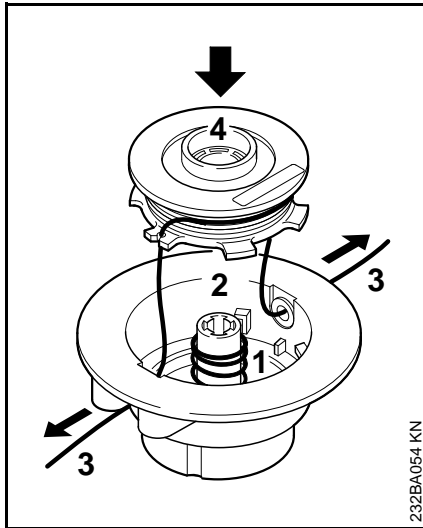

- Fit the spring (1) in the mowing head (2).
- Wind the mowing line (3) on to the spool (4).
- Thread the nylon line through the sleeves and fit the spool in the head.

The individual steps are described in the instruction sheet supplied.

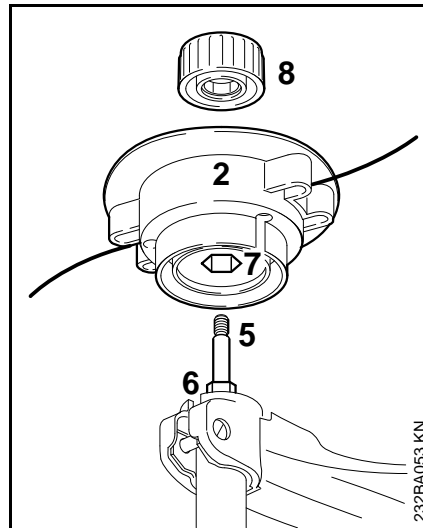

- Slip the mowing head (2) over the shaft (5) and engage hex recess (7) on the external hexagon (6).
- Fit the cap (8) on the mowing head – screw it clockwise on to the shaft as far as stop and tighten it down firmly.

STIHL AutoCut C 5-2

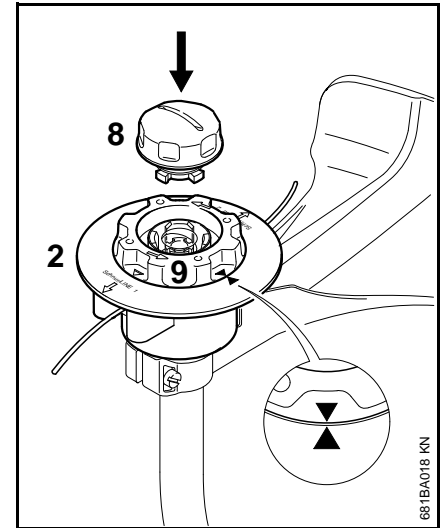

- Slip the mowing head (2) on to the shaft – as AutoCut 5-2.
- Turn the spool (9) clockwise until the two arrow heads line up – secure the spool in this position.
- Insert the cap (8) in the spool, press it down as far as stop and turn it clockwise at the same time.
- Turn the cap until you feel resistance and then tighten it down firmly by hand.

STIHL PolyCut 6-3

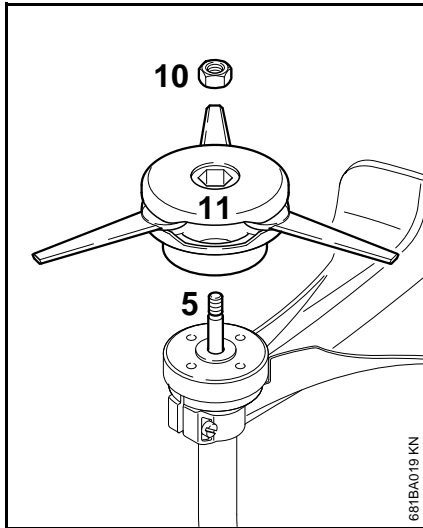

- Fit the thrust plate on the shaft.
- Insert the nut (10) in the mowing head.
- Screw the mowing head (11) clockwise on to the shaft (5) as far as stop.
- Block the shaft.
- Tighten down the mowing head firmly.

! WARNING

If the mounting nut has become too loose, fit a new one.

⚙ NOTICE

Remove the tool used to block the shaft.

STIHL FixCut 5-2

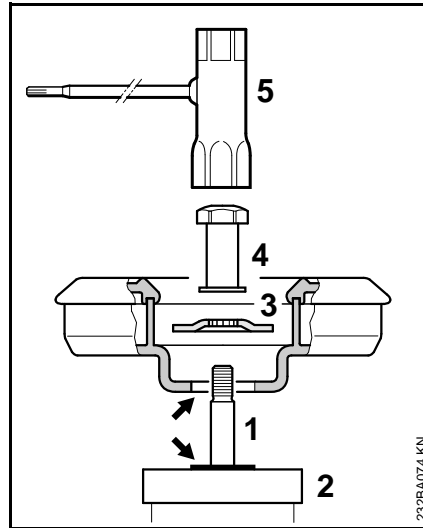

- Slip the thrust plate (2) over the shaft.
 - Place the mowing head on the thrust plate (2).
- ! WARNING**
- Collar (see arrows) must engage the mowing head's mounting hole.
- Push the thrust washer (3) over the shaft (1) so it is seated on the base.
 - Block the shaft.
 - Use the combination wrench (5) (special accessory) to screw the mounting nut (4) on to the output shaft and tighten it down firmly.

! WARNING

If the mounting nut has become too loose, fit a new one.

⚙ NOTICE

Remove the tool used to block the shaft.

Remove the mowing head.

STIHL AutoCut

- Hold the mowing head steady.
- Unscrew the cap counterclockwise.

STIHL PolyCut

- Block the shaft.
- Unscrew the mowing head counterclockwise.

STIHL FixCut

- Block the shaft.
- Use the combination wrench (special accessory) to loosen and unscrew the mounting nut counterclockwise from the output shaft.

Fuel

The engine requires a mixture of gasoline and engine oil.



WARNING

Avoid direct skin contact with and breathing in of gasoline fumes.

STIHL MotoMix

STIHL recommends using STIHL MotoMix. This pre-blended fuel is free of benzene and lead, stands out because of a high octane rating, and always provides the proper mixing ratio.

STIHL MotoMix is blended with STIHL HP Ultra two-stroke engine oil for maximum engine life.

MotoMix is not available in all markets.

Mixing fuel



NOTICE

Unsuitable fuels or a mixing ratio that deviates from the specification can lead to severe engine damage. The engine, seals, fuel lines and fuel tank may be damaged if poor quality gasoline or engine oil is used.

Gasoline

Use only **high-quality gasoline** with an octane rating of at least 90 ROC – leaded or unleaded.

Unleaded gasoline must be used in machines equipped with a catalytic converter.



NOTICE

Using multiple tankfuls of leaded gasoline can substantially reduce the effectiveness of the catalytic converter.

Gasoline with an alcohol component exceeding 10% can cause impaired engine performance in engines with manually adjustable carburetors and thus should not be used in these engines.

Engines with M-Tronic deliver full engine performance using gasoline with an alcohol component of up to 25% (E25).

Engine oil

Use only high-quality two-stroke engine oil – ideally **STIHL HP, HP Super or HP Ultra two-stroke engine oil, as they are specially engineered for STIHL engines. HP Ultra ensures maximum performance and engine life.**

The engine oils are not available in all markets.

Only **STIHL two-cycle engine oil 1:50** may be used to produce the fuel mixture for machines with a catalytic converter.

Mixing ratio

for STIHL two-cycle engine oil 1:50; 1:50 = 1 part oil + 50 parts gasoline

Examples

Quantity of gasoline	STIHL two-cycle engine oil 1:50	
Liters	Liters	(ml)
1	0.02	(20)
5	0.10	(100)
10	0.20	(200)
15	0.30	(300)
20	0.40	(400)
25	0.50	(500)

- Pour oil into an approved safety fuel canister first, then add gasoline and mix thoroughly

Storing fuel mixture

Store in approved safety fuel canisters only in a dry, cool and secure place protected against light and sunlight.

Fuel mixture ages – mix only as much as needed for a few weeks. Do not store fuel mixture for longer than three months. The fuel mixture can become unusable faster if exposed to light, sunlight or low or high temperatures.

- Shake the canister containing the fuel mixture thoroughly before refueling

! WARNING

Pressure can build up inside the canister – open carefully.

- The fuel tank and the canister in which fuel mixture is stored should be cleaned thoroughly from time to time

Residual fuel and the liquid used for cleaning must be disposed of in accordance with regulations and without harming the environment!

Fueling

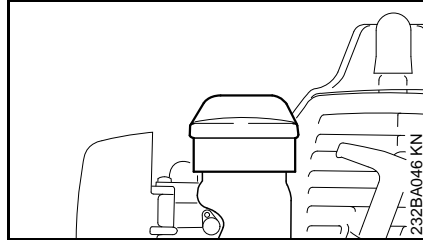

- Before fueling, clean the filler cap and the area around it to ensure that no dirt falls into the tank.
- Position the machine so that the filler cap is facing up.
- Open the filler cap.

Take care not to spill fuel while fueling and do not overfill the tank. STIHL recommends you use the STIHL filler nozzle (special accessory).

! WARNING

After fueling, tighten down the filler cap as securely as possible by hand.

Starting / Stopping the Engine

Controls

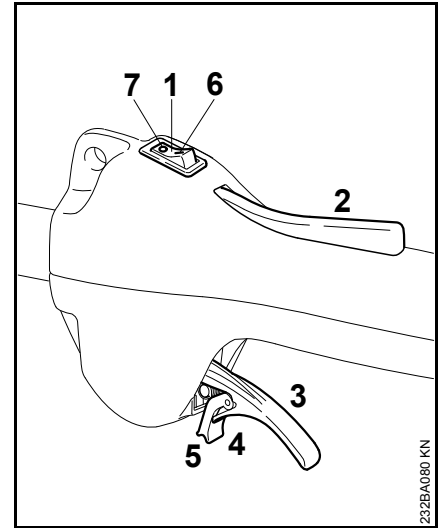

- 1 Stop switch
- 2 Throttle trigger lockout
- 3 Throttle trigger
- 4 Tongue of throttle trigger
- 5 Catch

Positions of stop switch

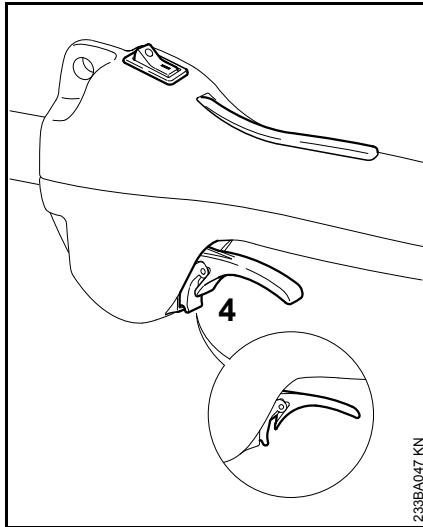

- 6 I – run
- 7 0 – stop

Starting

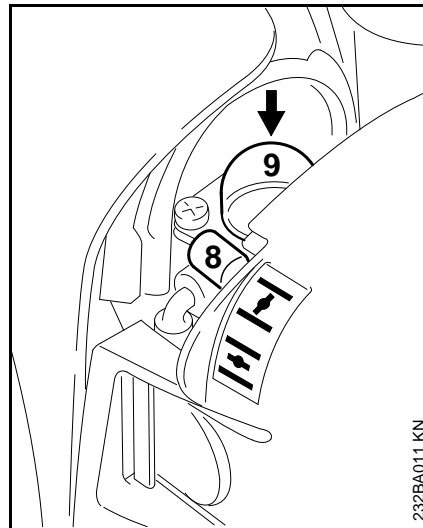

- Move the stop switch to I.
- Press down the throttle trigger lockout and hold it there.
- Squeeze the throttle trigger until the catch on the tongue (4) can be engaged on the housing (**arrow**).
- Now release the throttle trigger, tongue and trigger lockout in that order. This is the **starting throttle position**.



- Set the choke lever (8) to
 -  if the engine is cold
 -  for warm start – also use this position if the engine has been running but is still cold.
- Press the fuel pump bulb (9) at least five times – even if the bulb is already filled with fuel.

Starting

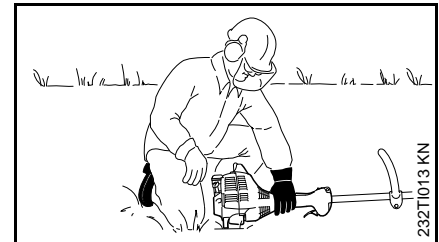
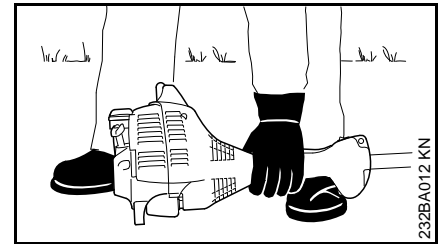

- Place the unit on the ground: It must rest securely on the engine support and the deflector. Check that the cutting attachment is not touching the ground or any other obstacles.
- Make sure you have a safe and secure footing.
- Hold the unit with your left hand and press it down **firmly** – your thumb should be under the fan housing.



Do not stand or kneel on the drive tube.

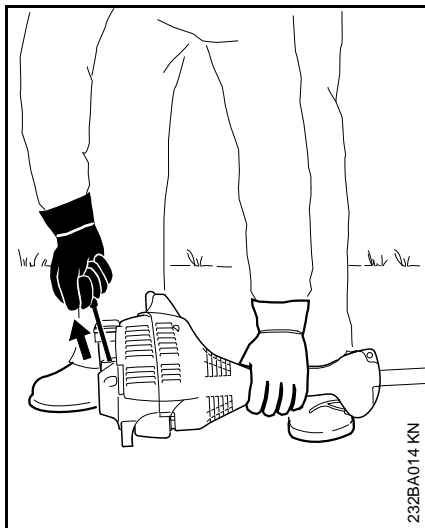

- Hold the starter grip with your right hand.
- Pull the starter grip slowly until you feel it engage and then give it a brisk strong pull.

NOTICE

Do not pull out the starter rope all the way – **it might otherwise break.**

- Do not let the starter grip snap back. Guide it slowly back into the housing so that the starter rope can rewind properly.
- Continue cranking.

When the engine begins to fire:

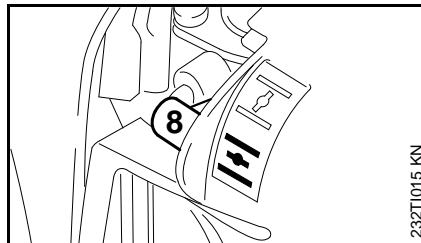

- After no more than **five** pulls, move the choke lever (8) to .
- Continue cranking.

As soon as the engine runs

- Squeeze the throttle trigger to disengage the tongue – the engine will settle down to idle speed.

WARNING

Make sure the carburetor is correctly adjusted. The cutting attachment must not rotate when the engine is idling.

Your machine is now ready for operation.

Stop the engine

- Move the stop switch to **0**.

If the engine does not start

Choke lever

If you did not move the choke lever to  quickly enough after the engine began to fire, the combustion chamber is flooded.

- Set the choke lever to .
- Move the stop switch to **I**, lockout lever and throttle trigger to the **starting throttle position**.
- Start the engine by pulling the starter rope briskly – 10 to 20 pulls may be necessary.

If the engine still does not start

- Move the stop switch to **0**.
- Remove the spark plug – see "Spark Plug".
- Dry the spark plug.
- Crank the engine several times with the starter to clear the combustion chamber.
- Refit the spark plug – see "Spark Plug".
- Move the stop switch to **I**.
- Set the choke lever to  – even if the engine is cold.
- Now start the engine.

Fuel tank run until completely dry

- After refueling, press the fuel pump bulb at least five times – even if the bulb is filled with fuel.
- Set the choke lever to suit the engine temperature.
- Start the engine.

Operating Instructions

During break-in period

A factory-new machine should not be run at high revs (full throttle off load) for the first three tank fillings. This avoids unnecessary high loads during the break-in period. As all moving parts have to bed in during the break-in period, the frictional resistances in the engine are greater during this period. The engine develops its maximum power after about 5 to 15 tank fillings.

During Operation

After a long period of full throttle operation, allow the engine to run for a short while at idle speed so that engine heat can be dissipated by the flow of cooling air. This protects engine-mounted components (ignition, carburetor) from thermal overload.

After Finishing Work

Storing for a short period: Wait for the engine to cool down. Empty the fuel tank and keep the machine in a dry place, well away from sources of ignition, until you need it again. For longer out-of-service periods – see "Storing the Machine".

Cleaning the Air Filter

If there is a noticeable loss of engine power

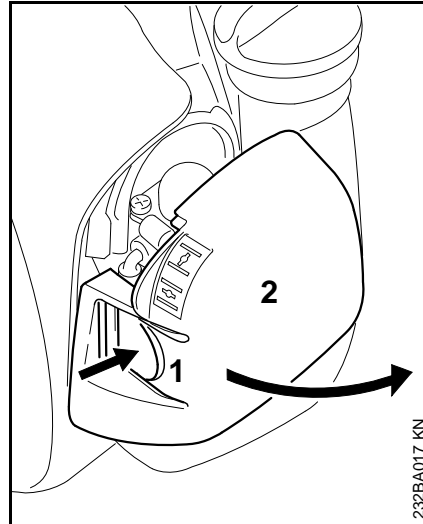

- Set the choke lever to **I**.
- Press in the tab (1) and swing the filter cover (2) down.
- Clean away loose dirt from around the filter.

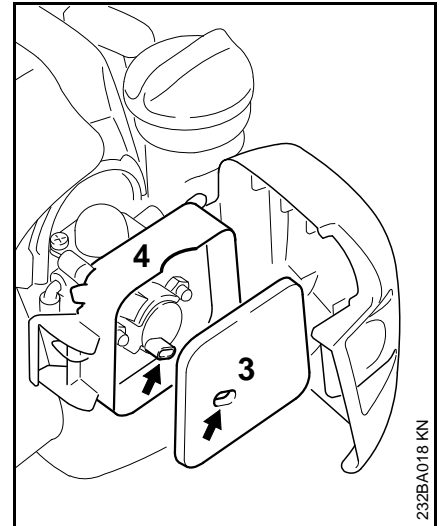

- Remove the felt element (3) from the filter housing (4) and replace it – knock out or blow out as a temporary measure – do not wash.
- Replace damaged parts.
- Fit the felt element (3) in the filter housing (4).
- Close the filter cover so that it snaps into position.

Adjusting the Carburetor

General Information

The carburetor comes from the factory with a standard setting.

This setting provides an optimum fuel-air mixture under most operating conditions.

Preparations

- Shut off the engine.
- Mounting the Cutting Attachment
- Check the air filter and clean or replace if necessary.
- Check the spark arresting screen (not in all models, country-specific) in the muffler and clean or replace if necessary.

FS 38 – Different Standard Settings

Different carburetors are installed at the factory. A different standard setting is necessary for each of these carburetors.

Standard setting A

- High speed screw (H) = 3/4
- Low speed screw (L) = 1 1/2

Standard setting B

- High speed screw (H) = 3/4
- Low speed screw (L) = 3/4

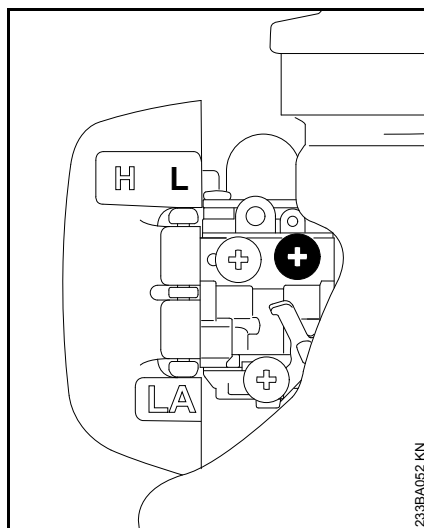

- Determine the standard setting as follows: Turn the low speed screw (L) carefully clockwise as far as stop, then turn it counterclockwise.

Is range of adjustment more than 1 turn?

- Continue with "**Standard setting A**"

Is range of adjustment less than 1 turn?

- Continue with "**Standard setting B**"

Standard setting A

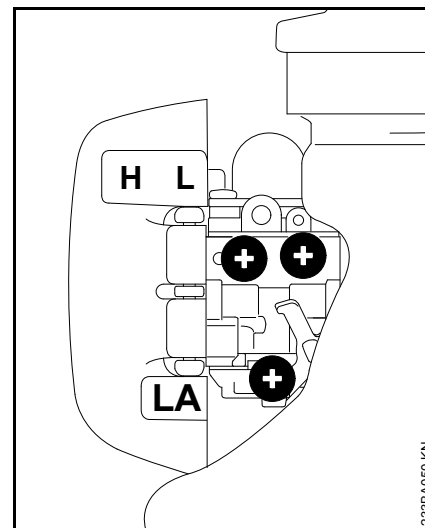

- Turn high speed screw (H) counterclockwise as far as stop (no more than 3/4 turn).
- Turn the low speed screw (L) carefully clockwise until it is against its seat, then turn it back 1 1/2 turns.

Standard setting B

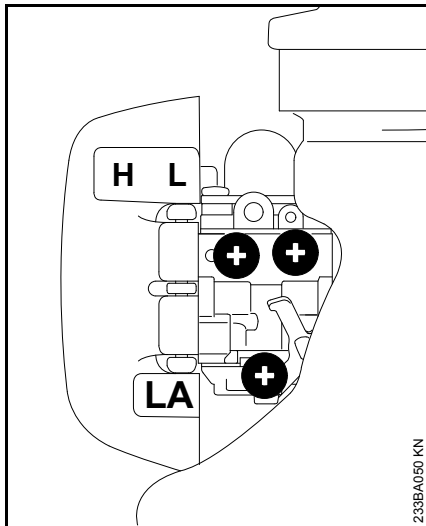

- Turn high speed screw (H) counterclockwise as far as stop (no more than 3/4 turn).
- Turn the low speed screw (L) carefully clockwise as far as stop, then turn it back 3/4 turn.

Standard Setting – FS 38 2-MIX

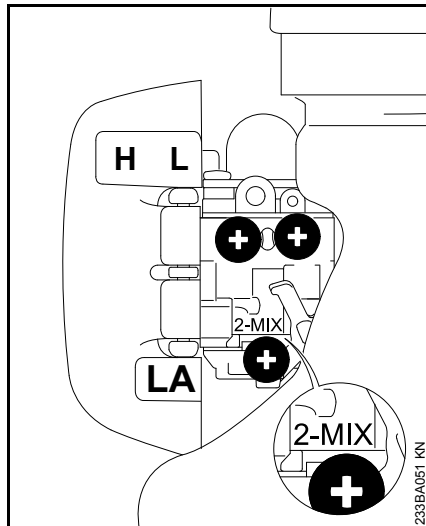

- Turn high speed screw (H) counterclockwise as far as stop (no more than 3/4 turn).
- Turn the low speed screw (L) carefully clockwise until it is against its seat, then turn it back 3/4 turn.

Adjusting Idle Speed – All Models

- Carry out the standard setting.
- Start and warm up the engine.

Engine stops while idling

- Turn the idle speed screw (LA) slowly clockwise until the engine runs smoothly – the cutting attachment must not rotate.

Cutting attachment rotates when engine is idling

- Turn the idle speed screw (LA) counterclockwise until the cutting attachment stops moving and then turn the screw another 1/2 to 1 full turn in the same direction.

! WARNING

If the cutting attachment continues to rotate when the engine is idling, have your machine checked and repaired by your servicing dealer.

Erratic idling behavior, poor acceleration (despite correction to setting of LA screw).

Idle setting is too lean

FS 38

- Rotate the low speed screw (L) slowly about 1/4 turn counterclockwise until the engine runs and accelerates smoothly.

FS 38 2-MIX

- Turn the low speed screw (L) counterclockwise, no further than stop, until the engine runs and accelerates smoothly.

Erratic idling behavior

Idle setting is too rich

FS 38

- Rotate the low speed screw (L) slowly about 1/4 turn clockwise until the engine runs smoothly and still accelerates satisfactorily.

FS 38 2-MIX

- Turn the low speed screw (L) slowly clockwise, no further than stop, until the engine runs and accelerates smoothly.

It is usually necessary to change the setting of the idle speed screw (LA) after every correction to the low speed screw (L).

Fine Tuning for Operation at High Altitude

A slight correction of the setting may be necessary if engine does not run satisfactorily:

- Carry out the standard setting.
- Warm up the engine.
- Turn high speed screw (H) slightly clockwise (leaner) – no further than stop.



NOTICE

After returning from high altitude, reset the carburetor to the standard setting.

If the setting is too lean there is a risk of engine damage due to insufficient lubrication and overheating.

Spark Plug

- If the engine is down on power, difficult to start or runs poorly at idle speed, first check the spark plug.
- Fit a new spark plug after about 100 operating hours – or sooner if the electrodes are badly eroded. Install only suppressed spark plugs of the type approved by STIHL – see "Specifications".

Removing the Spark Plug

- Move the stop switch to **0**.

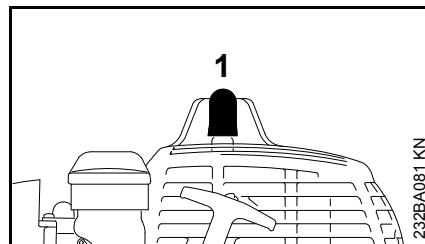

- Pull off the spark plug boot (1).
- Unscrew the spark plug.

Checking the spark plug

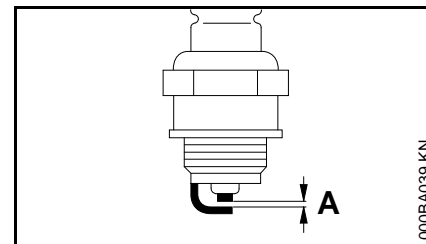

- Clean dirty spark plug.
- Check electrode gap (A) and readjust if necessary – see "Specifications".
- Rectify the problems which have caused fouling of the spark plug.

Possible causes are:

- Too much oil in fuel mix.
- Dirty air filter.
- Unfavorable running conditions.

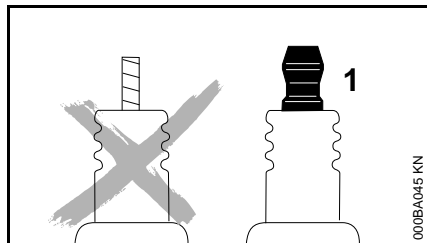

! WARNING

If the spark plug comes with a detachable adapter nut (1), screw the adapter onto the thread and tighten it down **firmly** to reduce the **risk of arcing and fire**.

Installing the spark plug

- Screw home the spark plug, fit the boot and press it down firmly.

Engine Running Behavior

If engine running behavior is unsatisfactory even though the air filter is clean and the carburetor is properly adjusted, the cause may be the muffler.

Have the muffler checked for contamination (carbonization) by your servicing dealer.

STIHL recommends that you have servicing and repair work carried out exclusively by an authorized STIHL servicing dealer.

Rewind Starter

To help prolong the wear life of the starter rope, observe the following points:

- Pull the starter rope only in the direction specified.
- Do not pull the rope over the edge of the guide bushing.
- Do not pull out the rope more than specified.
- Do not allow the starter grip to snap back, guide it back into the housing slowly – see chapter on "Starting / Stopping the Engine."

Have a damaged starter rope replaced by your dealer before it breaks completely. STIHL recommends that you have servicing and repair work carried out exclusively by an authorized STIHL servicing dealer.

Storing the Machine

For periods of 3 months or longer

- Drain and clean the fuel tank in a well ventilated area.
- Dispose of fuel properly in accordance with local environmental requirements.
- Run the engine until the carburetor is dry – this helps prevent the carburetor diaphragms sticking together.
- Remove, clean and inspect the cutting attachment.
- Thoroughly clean the machine – pay special attention to the cylinder fins and air filter.
- Store the machine in a dry and secure location – out of the reach of children and other unauthorized persons.

Maintaining the Mowing Head

Placing power tool on the ground

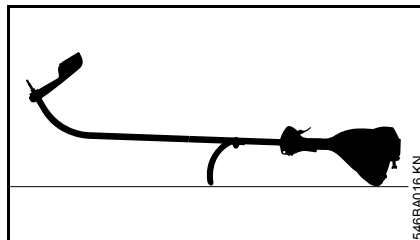

- Switch off the engine.
- Lay your trimmer on its back with the loop handle and shroud pointing down and the output shaft facing up.

Replacing Nylon Line

Always check the mowing head for signs of wear before replacing the nylon line.

WARNING

If there are signs of serious wear, replace the complete mowing head.

The nylon mowing line is referred to as "nylon line" or "line" in the following.

The mowing head is supplied with illustrated instructions for replacing the nylon line. Keep the instructions for the mowing head in a safe place.

- If necessary, remove the mowing head.

Adjusting Nylon Line

STIHL AutoCut

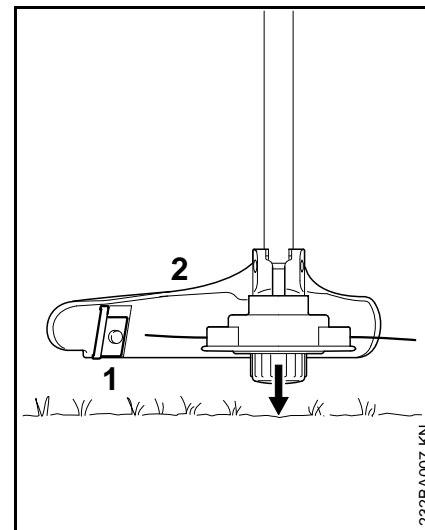

- Hold the rotating mowing head above the ground – tap it on the ground once – about 3 cm (1.2 in) of fresh line is advanced.
- The blade (1) on the deflector (2) trims surplus line to the correct length – avoid tapping the mowing head more than once at a time.

Line feed operates only if **both** lines still have a minimum length of **2.5 cm (1 in)**.

If the line is shorter than 2.5 cm (1 in):

WARNING

To reduce the risk of injury, always shut off the engine before adjusting the mowing line by hand.

English

- Turn the machine over.
- Press down the cap on the spool as far as stop.
- Pull the ends of the lines out of the spool.

If the spool is empty, refill with fresh lengths of nylon line.

All other mowing heads

Refer to the instructions supplied with the mowing head.

WARNING

To reduce the risk of injury, always shut off the engine before adjusting the mowing line by hand.

Replacing nylon line

STIHL DuroCut, STIHL FixCut

WARNING

To reduce the risk of injury, always shut off the engine before fitting new nylon line.

- Fit nylon line in mowing head as described in the instructions supplied.

STIHL AutoCut C 5-2

Disassembling the mowing head and removing remaining nylon line

In normal operation, the supply of nylon line in the head is used up almost completely.

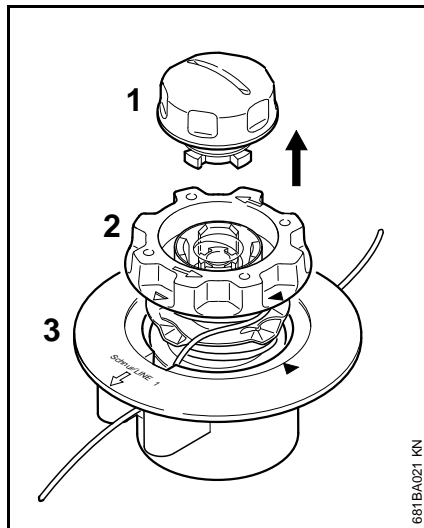

- Hold the mowing head steady and rotate the cap (1) counterclockwise until it can be removed.
- Pull the spool (2) out of the mowing head (3) and remove the remaining line.

Assembling the mowing head

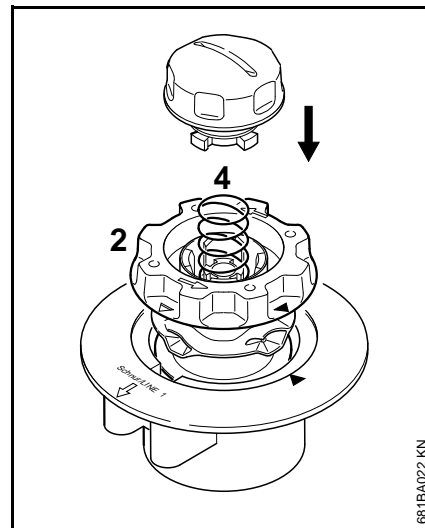

- Fit the **empty** spool in the mowing head.

If the spring (4) has popped out:

- push it into the spool (2) until it engages in position with an audible click.
- Mount the mowing head – see "Mounting the Mowing Head".

Winding line onto spool

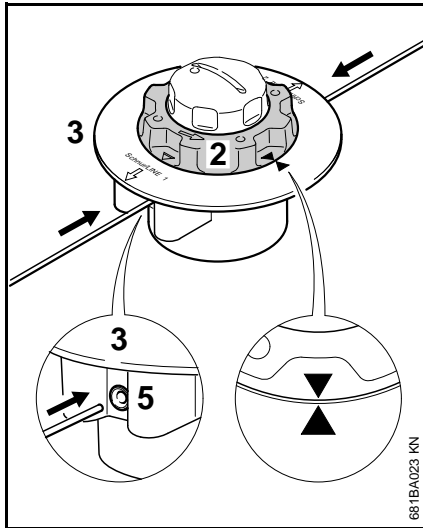

- Use green-coded nylon line with a diameter of 2.0 mm (0.08 in).
- Cut two 2 m (6ft 6in) lengths of nylon line from the reel (special accessory).
- Rotate the spool (2) counterclockwise until the two arrow points are in alignment.
- Push the **straight end of each line** through one sleeve (5) in the mowing head (3) until you feel a noticeable resistance – and then continue pushing as far as stop.

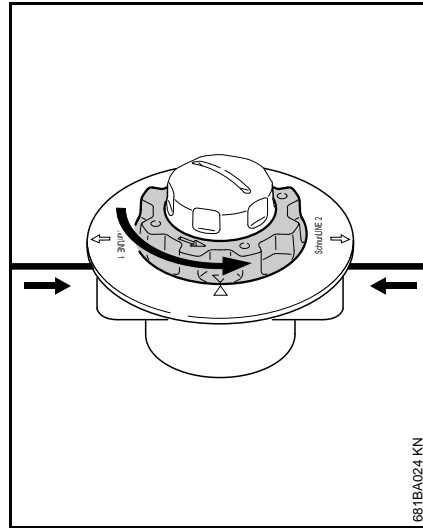

- Hold the mowing head steady.
- Rotate the spool counterclockwise until the shortest line is about 10 cm (4 in).
- If necessary, cut the longer line to a length of about 10 cm (4 in).

The mowing head is now full.

STIHL AutoCut 5-2

Removing remaining nylon line

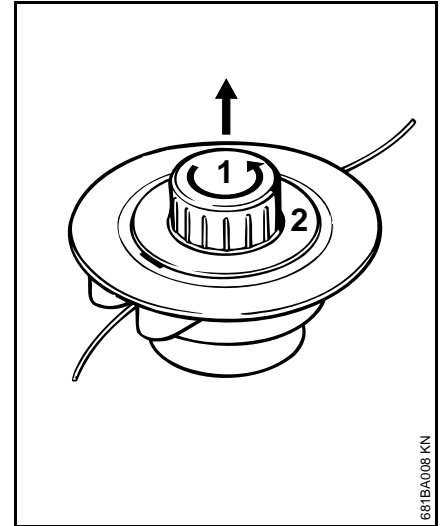

- Open the mowing head – hold it steady with one hand and turn the cap (1) counterclockwise.
- Disengage the spool (2), take it out of the mowing head and remove the remaining line.

Winding line onto spool

A prewound spool (special accessory) may be used as an alternative to the following procedure.

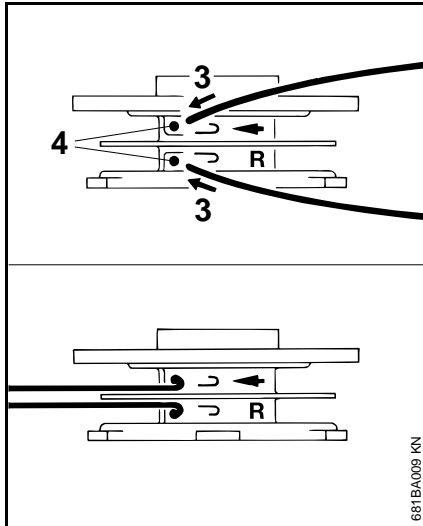

681BA009 KN

- Use green-coded nylon line with a diameter of 2.0 mm (0.08 in).
- Cut two 3 m (9ft 9in) lengths of nylon line from the reel (special accessory).
- Insert the ends of each line (3) in the holes (4) in the spool.
- Bend the ends of the lines over the edge of the holes to form a hook.

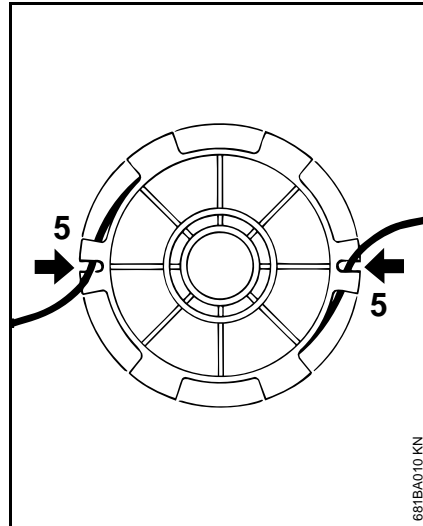

681BA010 KN

- Straighten out the nylon lines and wind them tightly on to the spool – one nylon line in each chamber.
- Engage the ends of the lines in the notches (2).

Assembling the mowing head



Check that the spring is installed (see "Mounting the Mowing Head").

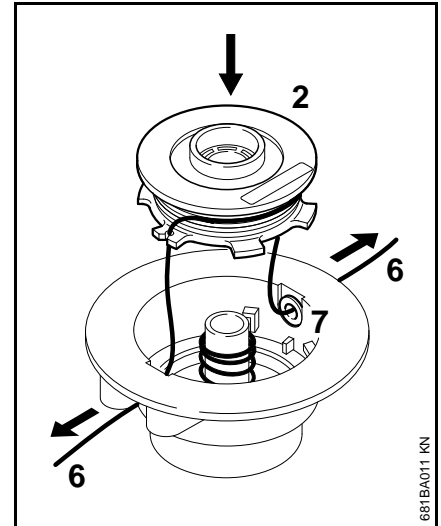

681BA011 KN

- Thread the ends of the lines (6) through the sleeves (7) and push the spool (2) into the head so that it snaps into position.

The nylon lines must disengage from the notches (5) as the spool is pushed into position.

- Pull out the ends of the lines as far as stop.
- Mount the mowing head on the machine.

Replacing Cutting Blades

STIHL PolyCut

Always check the mowing head for signs of wear before installing new cutting blades.

WARNING

If there are signs of serious wear, replace the complete mowing head.

The thermoplastic cutting blades are referred to as "blades" in the following.

The mowing head is supplied with illustrated instructions for replacing the blades. Keep the instructions for the mowing head in a safe place.

WARNING

To reduce the risk of injury, always shut off the engine before installing the blades.

- Remove the mowing head.
- Replace blades as shown in the illustrated instructions.
- Mount the mowing head on the machine.

Inspections and Maintenance by Dealer

Maintenance Work

STIHL recommends that you have servicing and repair work carried out exclusively by an authorized STIHL servicing dealer.

Fuel Pickup Body in Tank

- Have the pickup body in the fuel tank replaced every year.

Spark Arrestor in Muffler

- If the engine is low on power, have your dealer check the spark arrestor (country-specific option) in the muffler.

Maintenance and Care

The following intervals apply to normal operating conditions only. If your daily working time is longer or operating conditions are difficult (very dusty work area, etc.), shorten the specified intervals accordingly.		before starting work	after finishing work or daily	after each refueling stop	weekly	monthly	every 12 months	if problem	if damaged	if required
Complete machine	Visual inspection (condition, leaks)	X		X						
	Clean		X							
Control handle	Check operation	X		X						
Air filter	Clean							X		X
	Replace								X	
Pickup body in fuel tank	Have checked by dealer ¹⁾							X		
	Have replaced by dealer ¹⁾						X		X	X
Fuel tank	Clean							X		X
Carburetor	Check idle adjustment – the cutting attachment must not turn	X		X						
	Readjust idle									X
Spark plug	Readjust electrode gap							X		
	Replace after every 100 operating hours									
Cooling inlets	Visual Inspection		X							
	Clean									X
Spark arresting screen ²⁾ in muffler	Have checked by dealer ¹⁾		X					X		
	Have cleaned or replaced by servicing dealer ¹⁾								X	X
All accessible screws and nuts (not adjusting screws)	Retighten									X

The following intervals apply to normal operating conditions only. If your daily working time is longer or operating conditions are difficult (very dusty work area, etc.), shorten the specified intervals accordingly.		before starting work	after finishing work or daily	after each refueling stop	weekly	monthly	every 12 months	if problem	if damaged	if required
Cutting Attachment	Visual Inspection	X		X						
	Replace								X	
	Check tightness	X		X						
Safety labels	Replace								X	

1) STIHL recommends a STIHL servicing dealer.

2) not in all versions, market-specific

Minimize Wear and Avoid Damage

Observing the instructions in this manual helps reduce the risk of unnecessary wear and damage to the power tool.

The power tool must be operated, maintained and stored with the due care and attention described in this owner's manual.

The user is responsible for all damage caused by non-observance of the safety precautions, operating and maintenance instructions in this manual. This includes in particular:

- Alterations or modifications to the product not approved by STIHL.
- Using tools or accessories which are neither approved or suitable for the product or are of a poor quality.
- Using the product for purposes for which it was not designed.
- Using the product for sports or competitive events.
- Consequential damage caused by continuing to use the product with defective components.

Maintenance Work

All the operations described in the "Maintenance Chart" must be performed on a regular basis. If these maintenance operations cannot be performed by the owner, they should be performed by a servicing dealer.

STIHL recommends that you have servicing and repair work carried out exclusively by an authorized STIHL servicing dealer. STIHL dealers are regularly given the opportunity to attend training courses and are supplied with the necessary technical information.

If these maintenance operations are not carried out as specified, the user assumes responsibility for any damage that may occur. Among other parts, this includes:

- Damage to the engine due to neglect or deficient maintenance (e.g. air and fuel filters), incorrect carburetor adjustment or inadequate cleaning of cooling air inlets (intake ports, cylinder fins).
- Corrosion and other consequential damage resulting from improper storage.
- Damage to the machine resulting from the use of poor quality replacement parts.

Parts Subject to Wear and Tear

Some parts of the power tool are subject to normal wear and tear even during regular operation in accordance with instructions and, depending on the type and duration of use, have to be replaced in good time. Among other parts, this includes:

- Cutting attachments (all types)
- Mounting hardware for cutting attachments (rider plate, nut, etc.)
- Deflectors for cutting attachments
- Clutch
- Filters (air, fuel)
- Rewind starter
- Spark plug

Main Parts

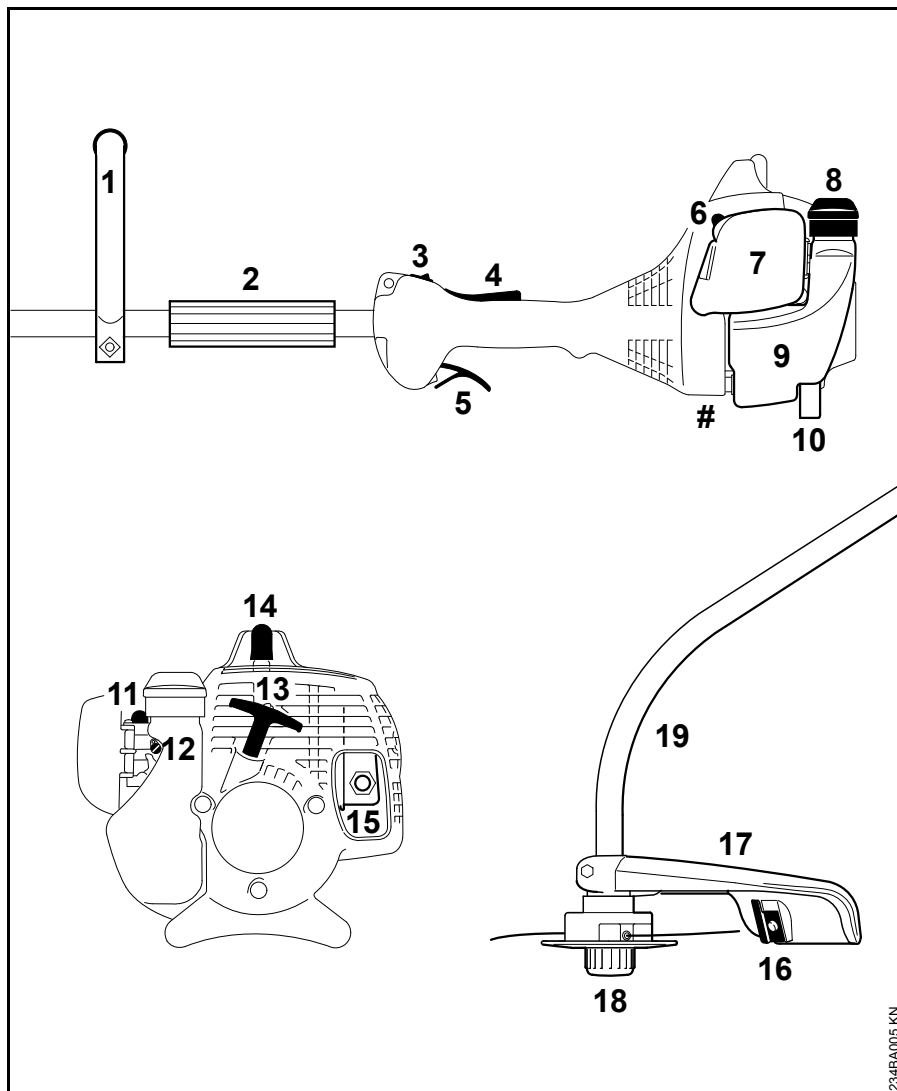

- 1 Loop handle
- 2 Sleeve
- 3 Stop switch
- 4 Throttle trigger interlock
- 5 Throttle trigger
- 6 Choke lever
- 7 Air filter cover
- 8 Fuel filler cap
- 9 Tank
- 10 Machine support
- 11 Fuel pump
- 12 Carburetor adjusting screws
- 13 Starter grip
- 14 Spark plug boot
- 15 Muffler (with spark arrestor in some markets)
- 16 Line limiting blade
- 17 Deflector
- 18 Mowing head
- 19 Drive tube
- # Serial number

234BA005 KN

Specifications

Engine

Single cylinder two-stroke engine

FS 38

Displacement:	27.2 cc
Bore:	34 mm
Stroke:	30 mm
Engine power to ISO 8893:	0.65 kW (0.9 bhp) at 7,000 rpm
Idle speed:	2,800 rpm
Cut-off speed (rated):	9,500 rpm
Max. output shaft speed (cutting attachment):	9,500 rpm

FS 38 2-MIX:

Displacement:	27.2 cc
Bore:	34 mm
Stroke:	30 mm
Engine power to ISO 8893:	0.65 kW (0.9 bhp) at 8,500 rpm
Idle speed:	2,800 rpm
Cut-off speed (rated):	9,500 rpm
Max. output shaft speed (cutting attachment):	9,500 rpm

Ignition System

Electronic magneto ignition

Spark plug (resistor type):	Bosch WSR 6 F, NGK BPMR 7 A
Electrode gap:	0.5 mm

Fuel System

All position diaphragm carburetor with integral fuel pump

Fuel tank capacity:	330 cc (0.33 l)
---------------------	-----------------

Weight

Dry, without cutting attachment and deflector

FS 38:	4.1 kg
FS 38 2-MIX:	4.2 kg

Noise and Vibration Data

Noise and vibration data measurements include idling and rated maximum speed with the same duration of exposure.

For further details on compliance with Vibration Directive 2002/44/EC see www.stihl.com/vib/

FS 38

Sound pressure level L_{peq} to ISO 7917

91 dB(A)

Sound power level L_{weq} to ISO 10884

103 dB(A)

Vibration measurement $a_{hv,eq}$ to ISO 22867

Handle, left	Handle, right
6.0 m/s ²	8.0 m/s ²

FS 38 2-MIX

Sound pressure level L_{peq} to ISO 22868

91 dB(A)

Sound power level L_{weq} to ISO 22868

104 dB(A)

Vibration measurement $a_{hv,eq}$ to ISO 22867

Handle, left	Handle, right
8.0 m/s ²	8.0 m/s ²

The K-factor in accordance with Directive 2006/42/EC is 2.5 dB(A) for the sound pressure level and sound power level; the K-factor in accordance with Directive 2006/42/EC is 2.0 m/s² for the vibration measurement.

REACH

REACH is an EC regulation and stands for the Registration, Evaluation, Authorisation and Restriction of Chemical substances.

For information on compliance with the REACH regulation (EC) No. 1907/2006 see www.stihl.com/reach.

Special Accessories

Cutting Attachments

Mowing heads

- 1 STIHL AutoCut C 5-2
- 2 STIHL AutoCut 5-2
- 3 STIHL FixCut 5-2
- 4 STIHL DuroCut 5-2
- 5 STIHL PolyCut 6-3



WARNING

Use cutting attachments only as specified in the chapter on "Approved Combinations of Cutting Attachment, Deflector, Handle and Harness".

Special accessories for cutting attachments

- Nylon line for mowing heads 1 to 4
- Serrated nylon line, pack of 48; for item 4
- Thermoplastic blades, pack of 12; for item 5

Mounting Hardware for Cutting Attachments

- Thrust plate
- Thrust washer
- Nut

Other Special Accessories

- Safety glasses
- Harness
- Combination wrench
- Stop pin
- Offset screwdriver
- Carburetor screwdriver
- STIHL ElastoStart (starter rope with grip)

Contact your STIHL dealer for more information on this and other special accessories.

Maintenance and Repairs

Users of this machine may only carry out the maintenance and service work described in this user manual. All other repairs must be carried out by a servicing dealer.

STIHL recommends that you have servicing and repair work carried out exclusively by an authorized STIHL servicing dealer. STIHL dealers are regularly given the opportunity to attend training courses and are supplied with the necessary technical information.

When repairing the machine, only use replacement parts which have been approved by STIHL for this power tool or are technically identical. Only use high-quality replacement parts in order to avoid the risk of accidents and damage to the machine.

STIHL recommends the use of original STIHL replacement parts.

Original STIHL parts can be identified by the STIHL part number, the **STIHL** logo and the STIHL parts symbol  (the symbol may appear alone on small parts).

Disposal

Observe all country-specific waste disposal rules and regulations.

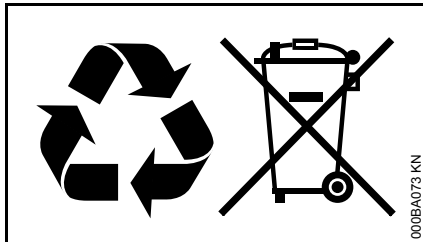

STIHL products must not be thrown in the garbage can. Take the product, accessories and packaging to an approved disposal site for environment-friendly recycling.

Contact your STIHL servicing dealer for the latest information on waste disposal.

EC Declaration of Conformity

ANDREAS STIHL AG & Co. KG
Badstr. 115
D-71336 Waiblingen

confirms that the product described below

Category:	Trimmer
Make:	STIHL
Model:	FS 38
Serial identification:	4140
Displacement:	27.2 cm ³

conforms to the specifications of Directives 2006/42/EC, 2004/108/EC and 2000/14/EC and has been developed and manufactured in compliance with the following standards:

EN ISO 11806, EN 55012,
EN 61000-6-1

The measured and guaranteed sound power levels were determined according to Directive 2000/14/EC, Annex V, using the ISO 10884 standard.

Measured sound power level

FS 38:	109 dB(A)
FS 38 2-MIX:	107 dB(A)

Guaranteed sound power level

FS 38:	110 dB(A)
FS 38 2-MIX:	109 dB(A)

Technical documents deposited at:
ANDREAS STIHL AG & Co. KG
Produktzulassung (Product Licensing)
The year of manufacture and serial number are applied to the product.
Done at Waiblingen, 01.08.2112
ANDREAS STIHL AG & Co. KG

A handwritten signature in black ink that reads 'Thomas Elsner'.

Thomas Elsner
Director Group Product Management

The CE mark, consisting of the letters 'C' and 'E' in a stylized, bold font.

0458-234-0121-B

englisch



www.stihl.com



0458-234-0121-B